

# bodytone

## SOLID GROW

### SG59

#### HACK SQUAT/LEG PRESS



## OWNER'S MANUAL

### !CAUTION!

Read all precautions and instructions in this manual before using this equipment.

# Table Of Contents

## CAUTION!

Read all precautions and instructions in this manual before using this equipment.

Important Safety Instructions-----	3
Instructions-----	5
Exploded View and Parts List-----	6
Measurement Guide-----	17
Assembly Instructions-----	18
Assembly-----	19
Adjust and Exercise Instruction-----	25
Maintenance Schedule-----	27
General Maintenance Information-----	28
Weight Training Tips-----	29

---

# Important Safety Instructions

Before beginning any fitness program, you should obtain a complete physical examination from your physician. When using exercise equipment, basic precautions should always be taken, including the following:

1. Read all instructions before using the equipment.  
These instructions are written to ensure your safety and to protect the unit.
2. Use the equipment only for its intended purpose as described in this guide.  
Do not use accessory attachments that are not recommended by the manufacturer: such attachments might cause injuries.
3. The product should only be used on a level surface and is with 0.6 meters space around the product.  
Do not use the equipment outdoors.
4. Do not allow children on or near the equipment. And children are not allowed to use this equipment.  
Teenagers should use this equipment with adult supervision.
5. Do not overexert yourself or work to exhaustion.  
Do not attempt to lift more weight than you can control safely.  
If you feel any pain or abnormal symptoms, stop your workout immediately and consult your physician.
6. This equipment is not used as medical apparatus and instruments.
7. Never operate the unit when it has been dropped or damaged.  
Never drop or insert anything into any opening in the equipment.  
Always check the unit and its cables before each use. Make sure that all fasteners and cables are secure and in good working condition.  
Frayed or worn cables can be dangerous and may cause injury. Periodically check these cables for any indication of wear.  
Keep hands, limbs, loose clothing and long hair well out of the way of moving parts.
8. Be careful when getting on or off the equipment.
9. Wear proper exercise clothing and shoes for your workout, no loose clothing.

# Important Safety Instructions

## Personal Safety During Assembly

Read each step in the assembly instructions and follow the steps in sequence. Do not skip ahead. If you skip ahead, you may learn later that you have to disassemble components and that you may have damaged the equipment.

Assemble and operate the equipment on a solid, level surface. Locate the unit a few feet from walls or furniture to provide easy access. The equipment is designed for your enjoyment. By following these precautions and using common sense, you will have many safe and pleasurable hours of healthful exercise with the equipment.

## Training Area and Free Area

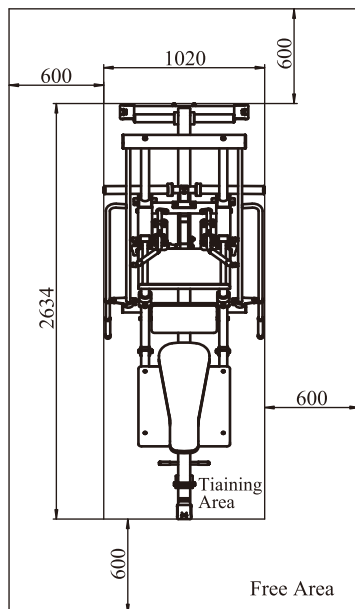

### Specifications

Class: S

Maximum Wt. Capacity: 2\*175kg/ 386lbs

Maximum User Weight: 150kg/ 330lbs

Product Dimension: 2634\*1020\*1373mm

Product Total Surface: 2634\*1020mm

Product Total Mass: 150.5kg/ 332lbs

# Instructions

Before beginning assembly please take the time to read instructions thoroughly. Please use the various lists in this manual to make sure that all parts have been included in your shipment. When ordering, use part number and description from the lists. Use only our replacement part when servicing. Failure to do so will void your warranty and could result in personal injury.

The equipment is designed to provide the smoothest, most effective exercise motion possible. After assembly, you should check all functions to ensure correct operation. If you experience problems, first recheck the assembly instructions to locate any possible errors made during assembly. If you are unable to correct the problem, call your authorized dealer. Be sure to have your serial number and this manual when calling. When all parts have been accounted for, continue on.

## Tools Required

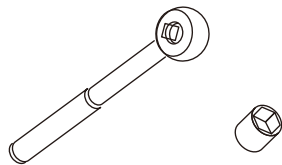

Ratchet Wrench and Socket

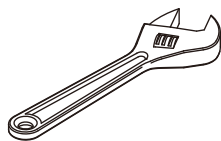

Adjustable Wrench

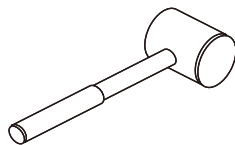

Rubber Mallet

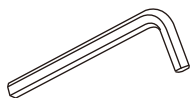

Hex Key Wrench Set

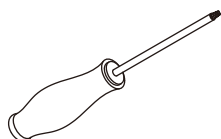

Phillips Screwdriver

# Exploded View and Parts List

## Overall

Item No.	Part No.	Description	QTY
1	IFP171101ASSY	Back Connect Frame ASSY	1
2	IFP171102ASSY	Back Upright Frame ASSY	1
3	IFP17110300	Bottom Frame	1
4	IFP171108ASSY	Barbell Frame ASSY	1
5	IFP171109ASSY	Right Safe Frame ASSY	1
6	IFP171110ASSY	Left Safe Frame ASSY	1
7	IFP171115ASSY	Guide Frame ASSY	2
8	IFP171120ASSY	Handle Frame ASSY	2
9	TCB-550800	Pad bracket	4
10	IT70065800V1	Shoulder Pad	2
11	IT70065900V1	Seat pad	1
12	IFP171136ASSY	Back Pad ASSY	1
13	IFP171104ASSY	Right Support Frame ASSY	1
14	IFP171105ASSY	Left Support Frame ASSY	1
15	IFP171106ASSY	Carriage ASSY	1
16	IFP171107SGASSY	Adjustable Frame ASSY	1
17	IFP171111ASSY	Shoulder Handle Frame ASSY	2
18	IFP171112ASSY	Upper Pedal ASSY	1
19	IFP171113ASSY	Bottom Pedal ASSY II	1
20	IFP171114SGASSY	Adjustable Back Pad Frame ASSY	1
21	GB5781M6*15DHS2	Hex Head Cap Screw M6*15	2
22	GB5781M10*20DHS20	Hex Head Cap Screw M10*20	10
23	GB5781M10*25DHS20	Hex Head Cap Screw M10*25	2
24	GB5781M10*30DHS20	Hex Head Cap Screw M10*30	4
25	GB5780M10*75DHS20	Hex Head Cap Screw M10*75	7
26	GB5780M10*70DHS20	Hex Head Cap Screw M10*70	12
27	GB5780M10*100DHS20	Hex Head Cap Screw M10*100	2
28	GB5781M12*30DHS20NL	Hex Head Cap Screw M12*30	2
29	GB5780M12*80DHS20	Hex Head Cap Screw M12*80	2
30	GB5780M12*85DHS20	Hex Head Cap Screw M12*85	2
31	GB5780M12*125DHS20	Hex Head Cap Screw M12*125	1
32	GB9510DHS2	Flat Washer $\Phi 11*\Phi 20*2$	62
33	GB9512DHS2	Flat Washer $\Phi 13*\Phi 24*2.5$	12
34	GB9312DHS12	Spring Washer $\Phi 12$	2
35	NM10DHS2	Nylon Lock Nut M10	25
36	NM12DHS2	Nylon Lock Nut M12	5
37	NBS6DHS	Hex Key S=6	1

# Exploded View and Parts List

## Overall

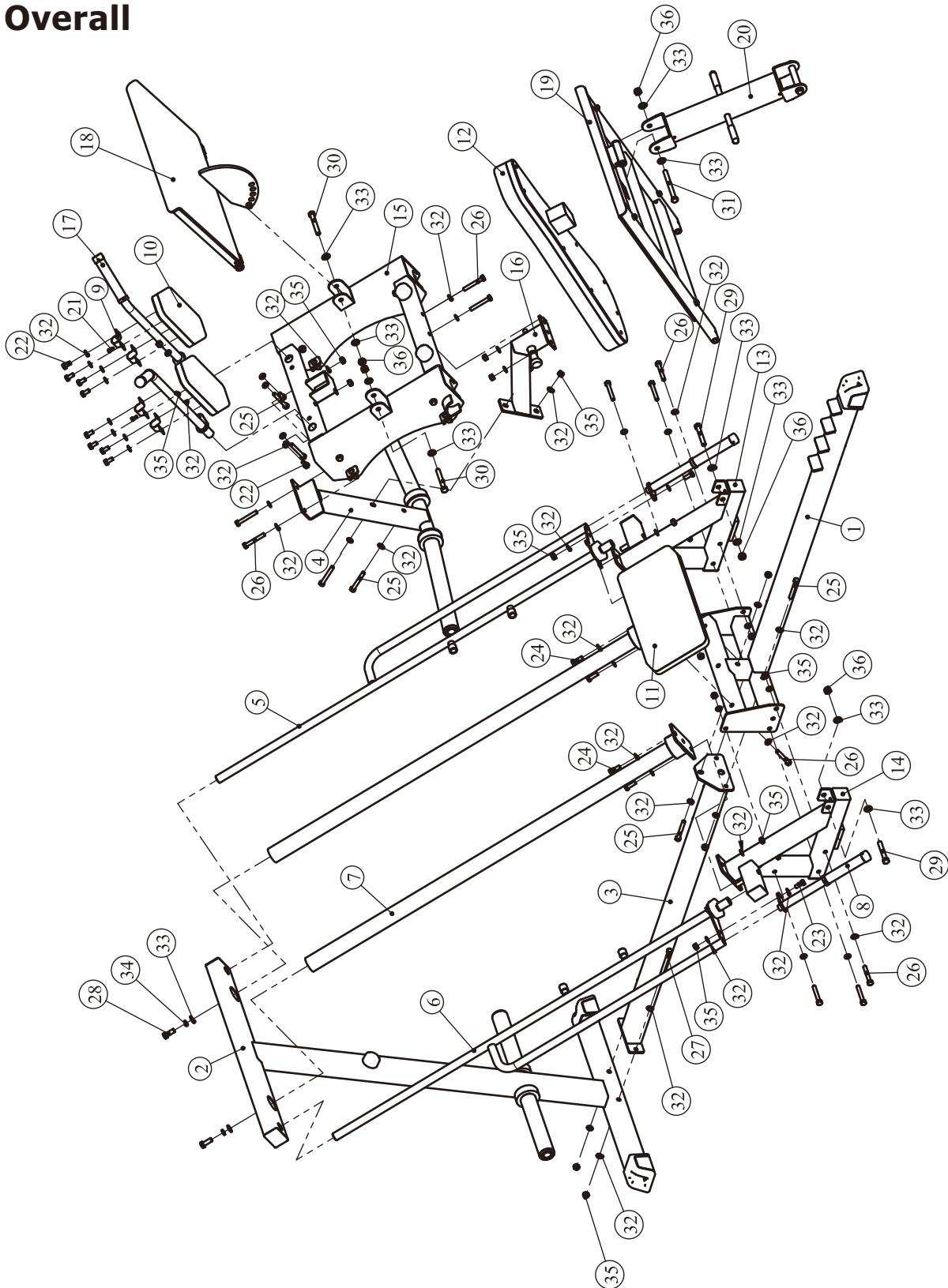

# Exploded View and Parts List

## Back Connect Frame ASSY    Back Upright Frame ASSY

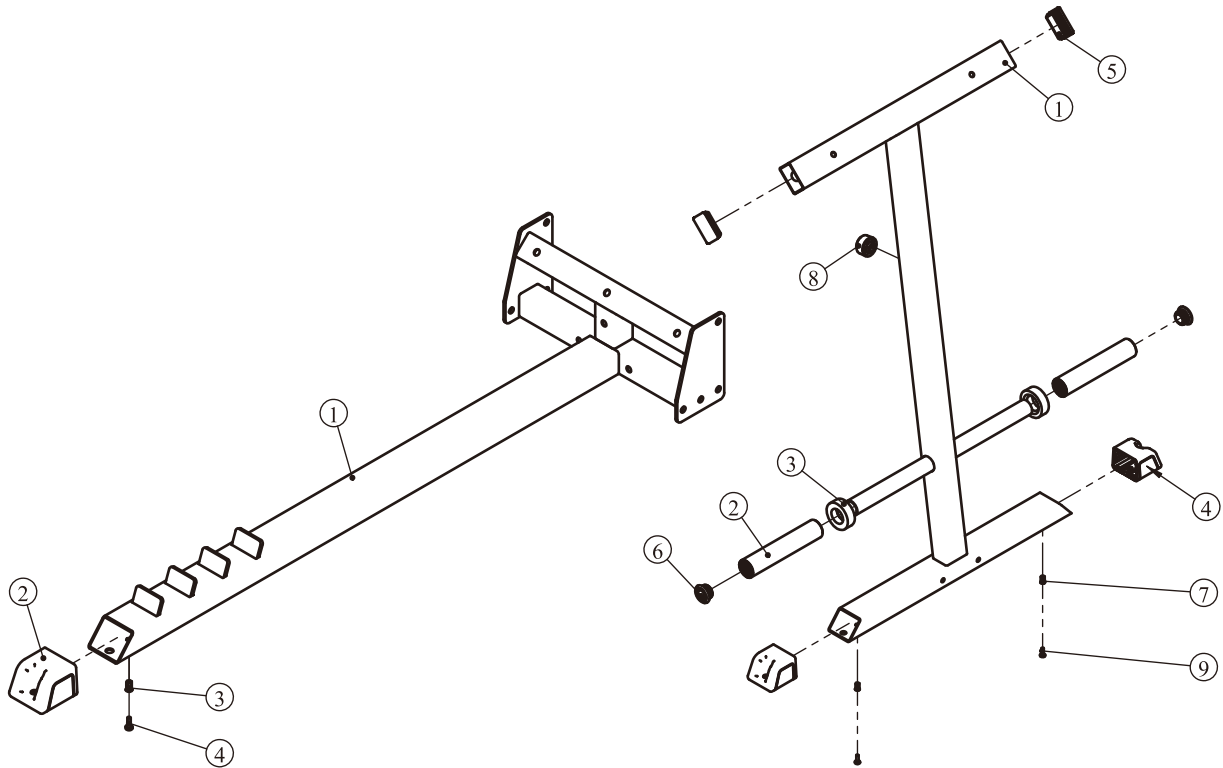

Grade No.	Part No.	Description	QTY
1.1	IFP17110100	Back Bottom Frame	1
1.2	IFP12013300	Bottom Foot Plug	1
1.3	GB17880.5M6*16.5DS17	Rivet Nut M6	1
1.4	GB818M6*20DHS2	Cross Recessed Pan Head Screw M6*20	1

Grade No.	Part No.	Description	QTY
2.1	IFP17110200	Upright Frame	1
2.2	IFP12013400	Weight Horn Sleeve	2
2.3	HF985A1500	Bumper	2
2.4	IFP12013300	Bottom Foot Plug	2
2.5	KPSFID2800	Plug □76.2*50.8	2
2.6	IFP12013500	Plug Φ49	2
2.7	GB17880.5M6*16.5DS17	Rivet Nut M6	2
2.8	CW40393-101	Cushion	1
2.9	GB818M6*20DHS2	Cross Recessed Pan Head Screw M6*20	2



# Exploded View and Parts List

## Barbell Frame ASSY

## Back Pad ASSY

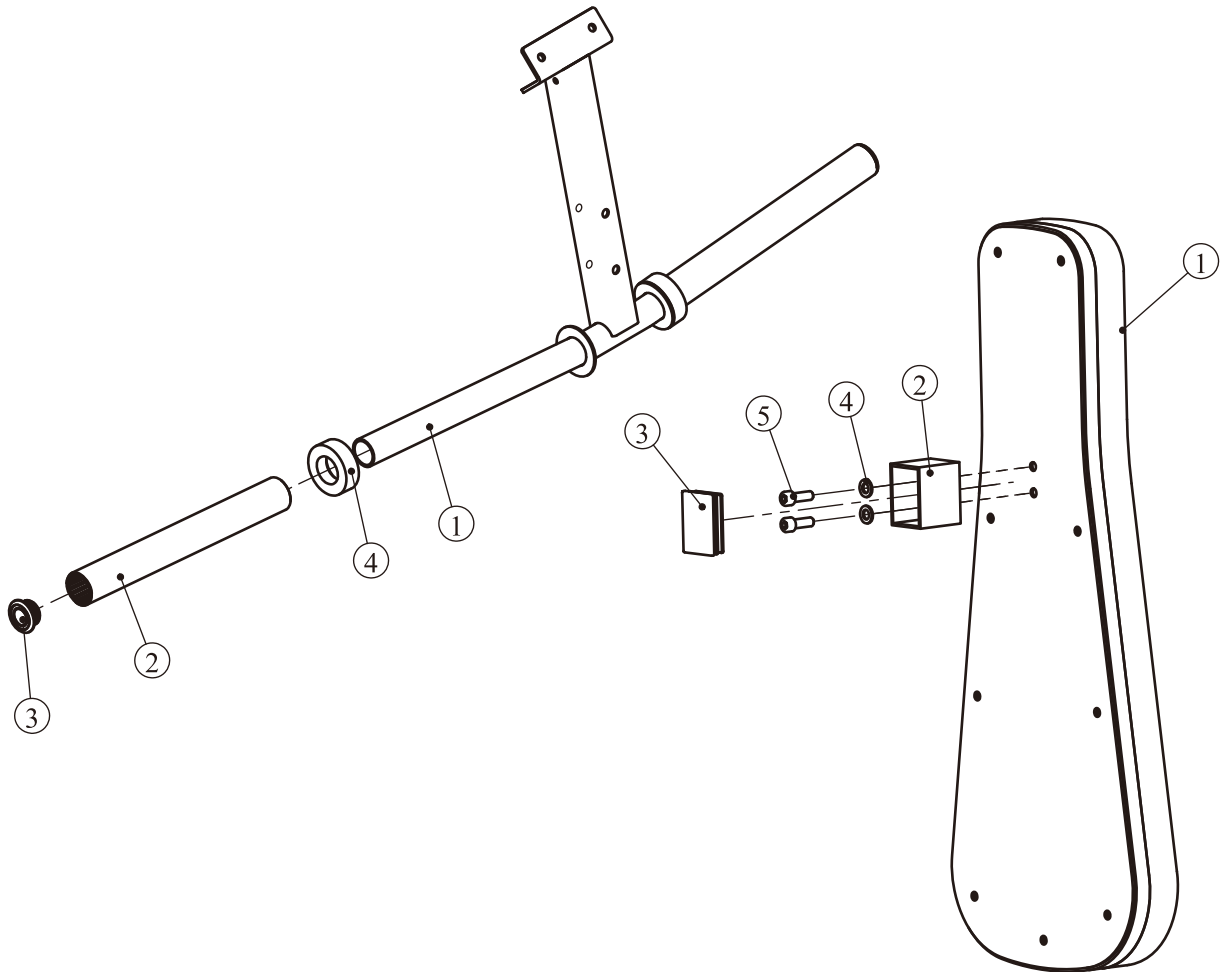

Grade No.	Part No.	Description	QTY
4.1	IFP17110800	Barbell Frame	1
4.2	IFP17113400	Long Weight Horn Sleeve	2
4.3	IFP12013500	Plug $\Phi 49$	2
4.4	HF985A1500	Bumper	2

Grade No.	Part No.	Description	QTY
12.1	IT70066000V1	Back Pad	1
12.2	IT60061300	Back Pad Frame	1
12.3	PBF30036	Plug $\square 50*70$	1
12.4	GB9510DHS2	Flat Washer $\Phi 11*\Phi 20*2$	2
12.5	GB70M10*30DHS20	Socket Head Cap Screw M10*30	2

# Exploded View and Parts List

## Right Safe Frame ASSY

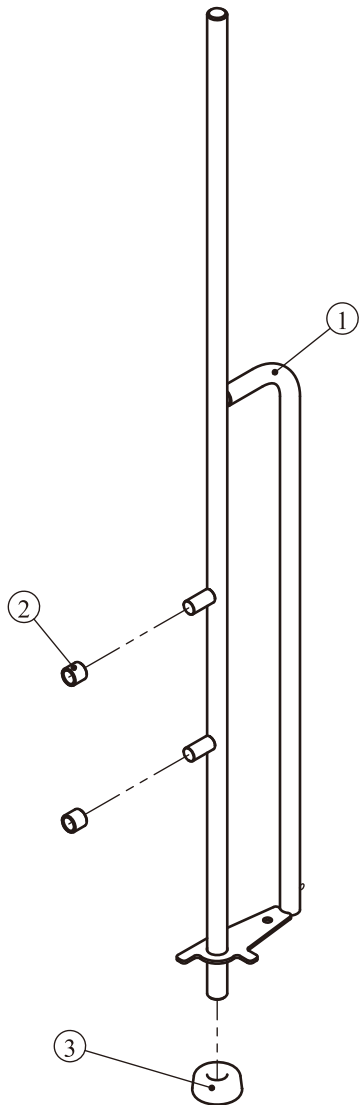

## Left Safe Frame ASSY

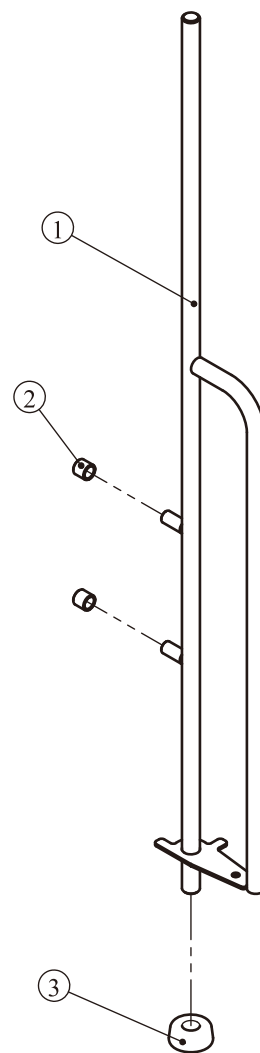

Grade No.	Part No.	Description	QTY
5.1	IFP17110900	Right Safe Frame	1
5.2	BH97213100	Stop Collar	2
5.3	BNH0062-1	Bumper	1

Grade No.	Part No.	Description	QTY
6.1	IFP17111000	Left Safe Frame	1
6.2	BH97213100	Stop Collar	2
6.3	BNH0062-1	Bumper	1

# Exploded View and Parts List

## Guide Frame ASSY

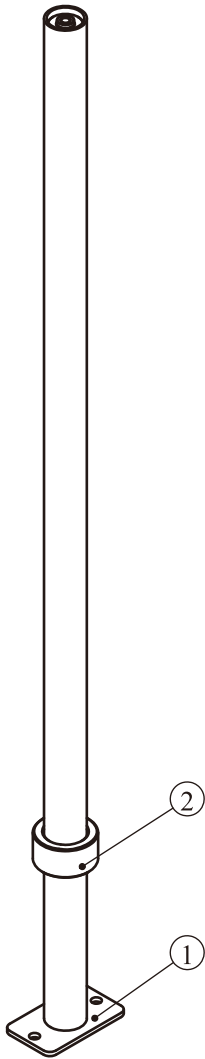

## Handle Frame ASSY

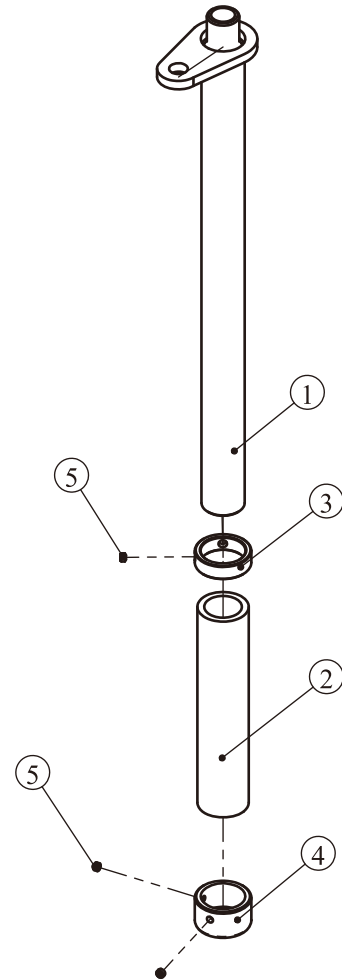

Grade No.	Part No.	Description	QTY
7.1	IFP17111500	Guide Frame	1
7.2	026-01PL2909	Bumper	1

Grade No.	Part No.	Description	QTY
8.1	IFP17112000	Handle Frame	1
8.2	FE97031800	Grip	1
8.3	V39500	Aluminum Grip Ring	1
8.4	V39600	Aluminum Grip Cap	1
8.5	YZGB7710-32*3.2N19	Socket Set Screw 10-32UNF*3.2	4

# Exploded View and Parts List

## Right Support Frame ASSY    Left Support Frame ASSY

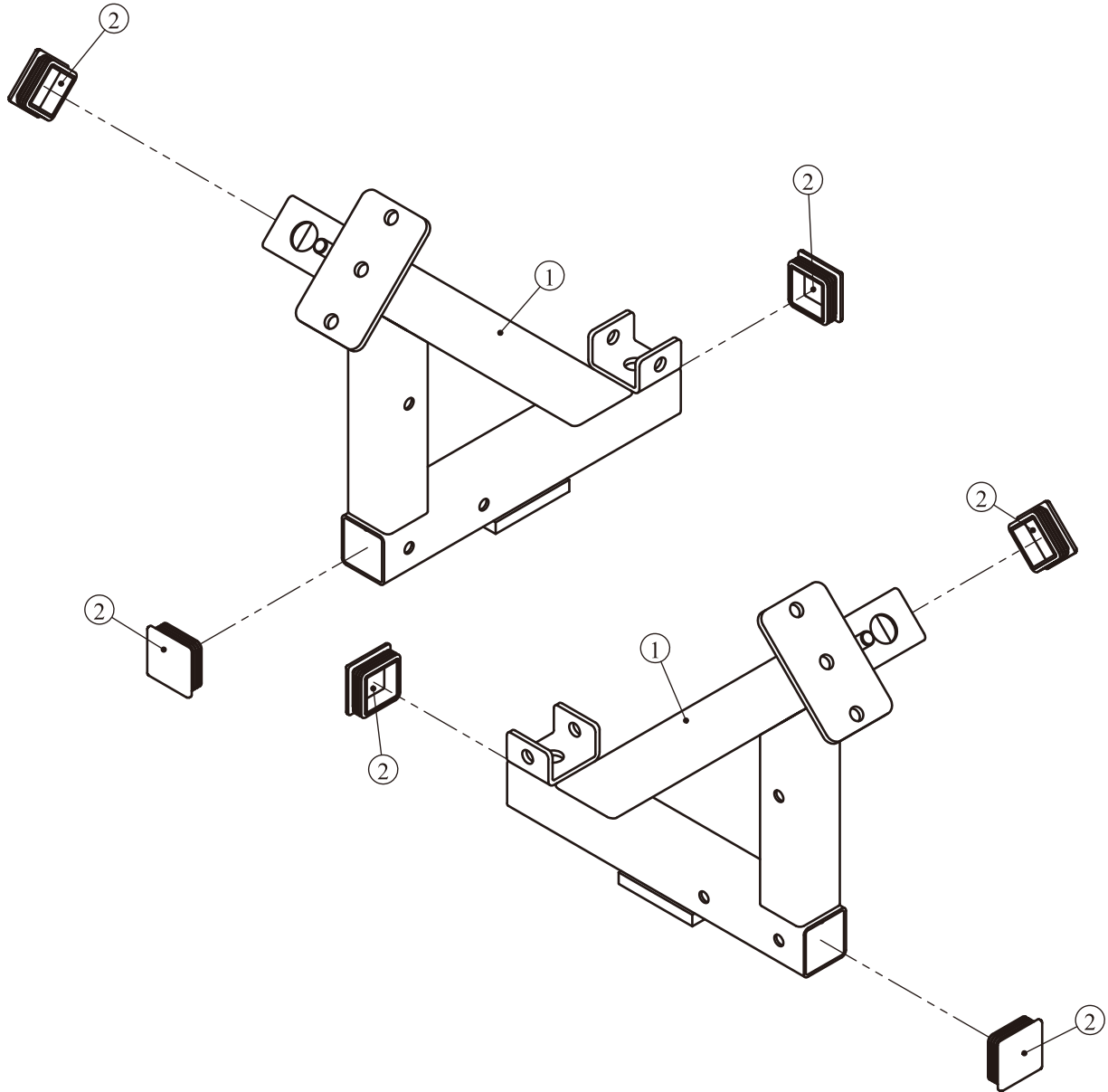

Grade No.	Part No.	Description	QTY
13.1	IFP17110400	Right Support Frame	1
13.2	KPSFID3000	Plug □50.8	3

Grade No.	Part No.	Description	QTY
14.1	IFP17110500	Left Support Frame	1
14.2	KPSFID3000	Plug □50.8	3

# Exploded View and Parts List

## Carriage ASSY

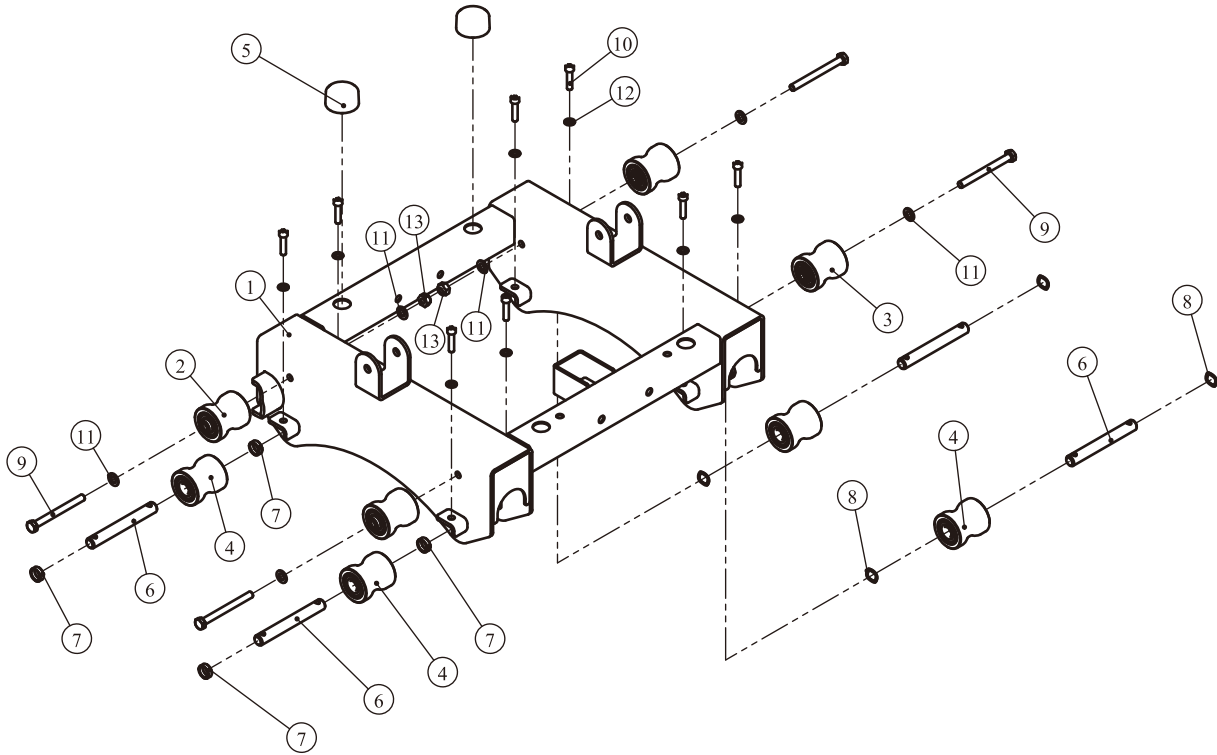

Grade No.	Part No.	Description	QTY
15.1	IFP17110600	Carriage	1
15.2	IT951010ASSY	Roller Group1	2
15.3	IT951011ASSY	Roller Group2	2
15.4	BH971010ASSY	Roller Group	4
15.5	CW40393-101	Bumper	2
15.6	BH97102200	Adjusting Shaft	4
15.7	FE97122100	Pulleys Spacer	4
15.8	YBDQ23*17.3*0.4DHS12	Eccentric Washer	4
15.9	GB5780M10*105DHS20	Hex Head Cap Screw M10*105	4
15.10	GB70M8*40*40DHS2	Socket Head Cap Screw M8*40	8
15.11	GB9510DHS2	Flat Washer $\Phi 11*\Phi 20*2$	8
15.12	GB958DHS2	Flat Washer $\Phi 9*\Phi 16*1.6$	8
15.13	NM10DHS2	Nylon Lock Nut M10	4

# Exploded View and Parts List

## Adjustable Frame ASSY Shoulder Handle Frame ASSY

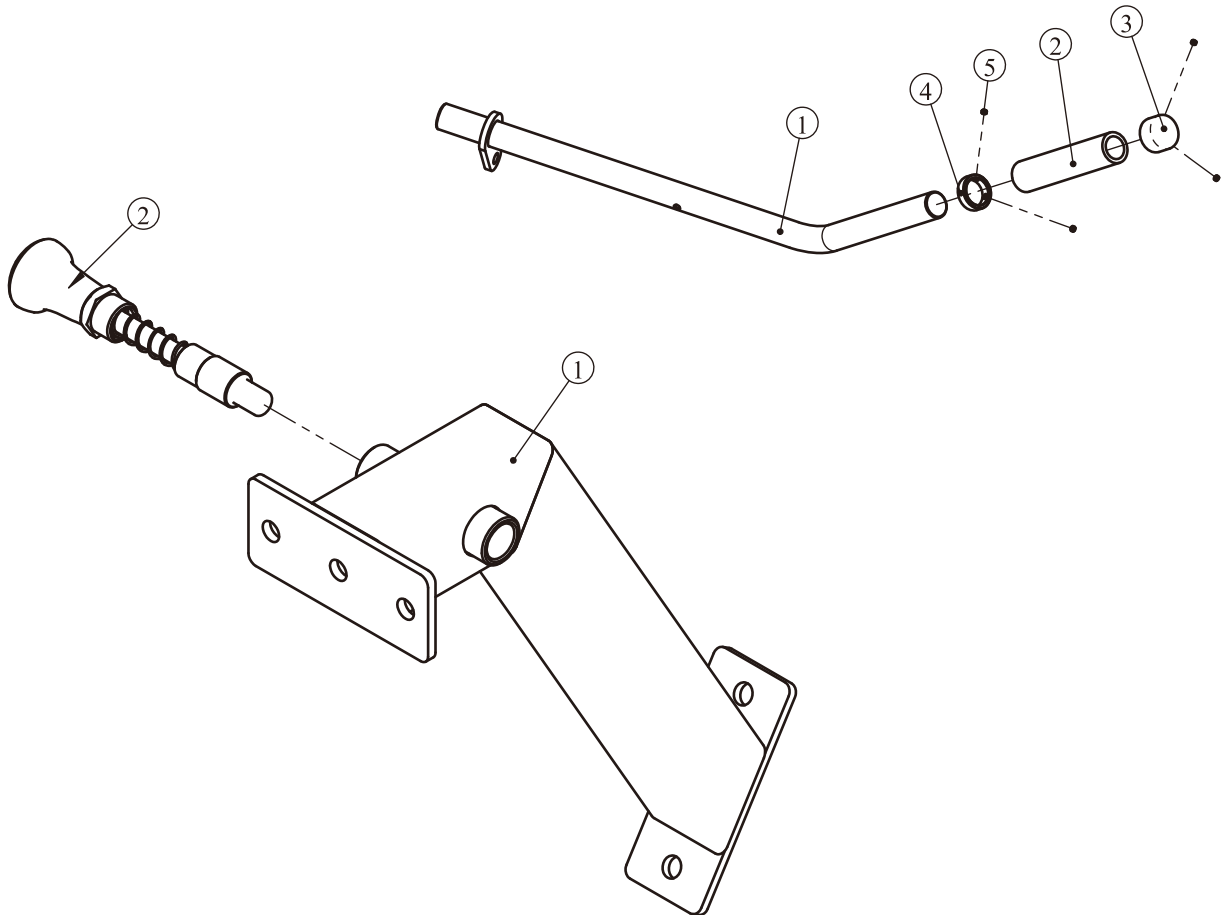

Grade No.	Part No.	Description	QTY
16.1	IFP17110700	Adjustable Frame	1
16.2	IT95151500P201C	Pin	1

Grade No.	Part No.	Description	QTY
17.1	IFP17111100	Shoulder Handle Frame	1
17.2	FE97031800	Grip	1
17.3	V39600	Aluminum Grip Ring	1
17.4	V39500	Aluminum Grip Cap	1
17.5	YZGB7710-32*3.2N19	Socket Set Screw 10-32UNF*3.2	4

# Exploded View and Parts List

## Upper Pedal ASSY

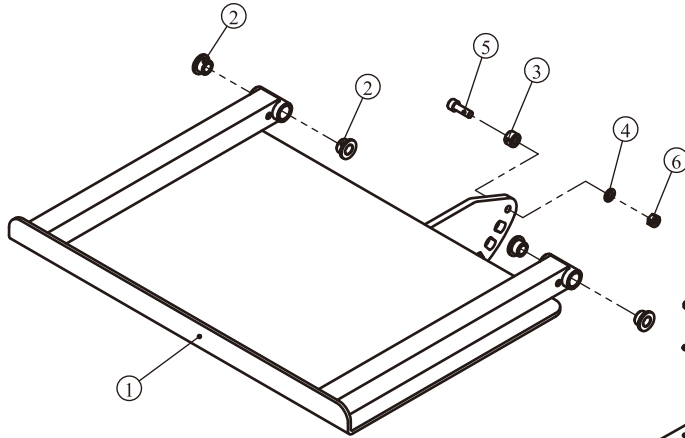

## Bottom Pedal ASSY II

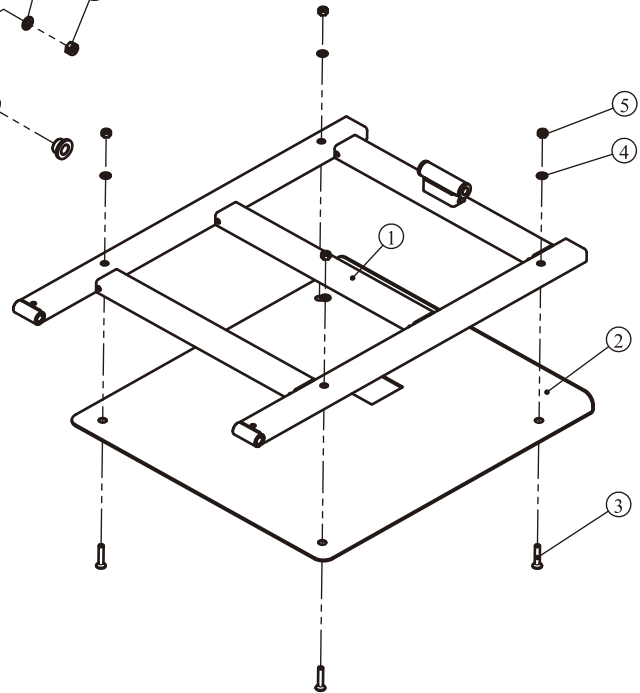

Grade No.	Part No.	Description	QTY
18.1	IFP17111200	Upper Pedal Frame	1
18.2	M01402000	Barbell Plug Bumper	4
18.3	IN-S10111200	Stop Collar	1
18.4	GB958DHS2	Flat Washer $\Phi 9 * \Phi 16 * 1.6$	1
18.5	GB70M8*25DHS20	Socket Head Cap Screw M8*25	1
18.6	NM8DHS2	Nylon Lock Nut M8	1

Grade No.	Part No.	Description	QTY
19.1	IFP17111300ASSY	Bottom Pedal ASSY I	1
19.2	IFP17111800	Pedal Plate	1
19.3	CNLM8*40DHS20	Flat Head Cap Screw M8*40	4
19.4	GB958DHS2	Flat Washer $\Phi 9 * \Phi 16 * 1.6$	4
19.5	NM8DHS2	Nylon Lock Nut M8	4

# Exploded View and Parts List

## Bottom Pedal ASSY I

## Adjustable Back Pad Frame ASSY

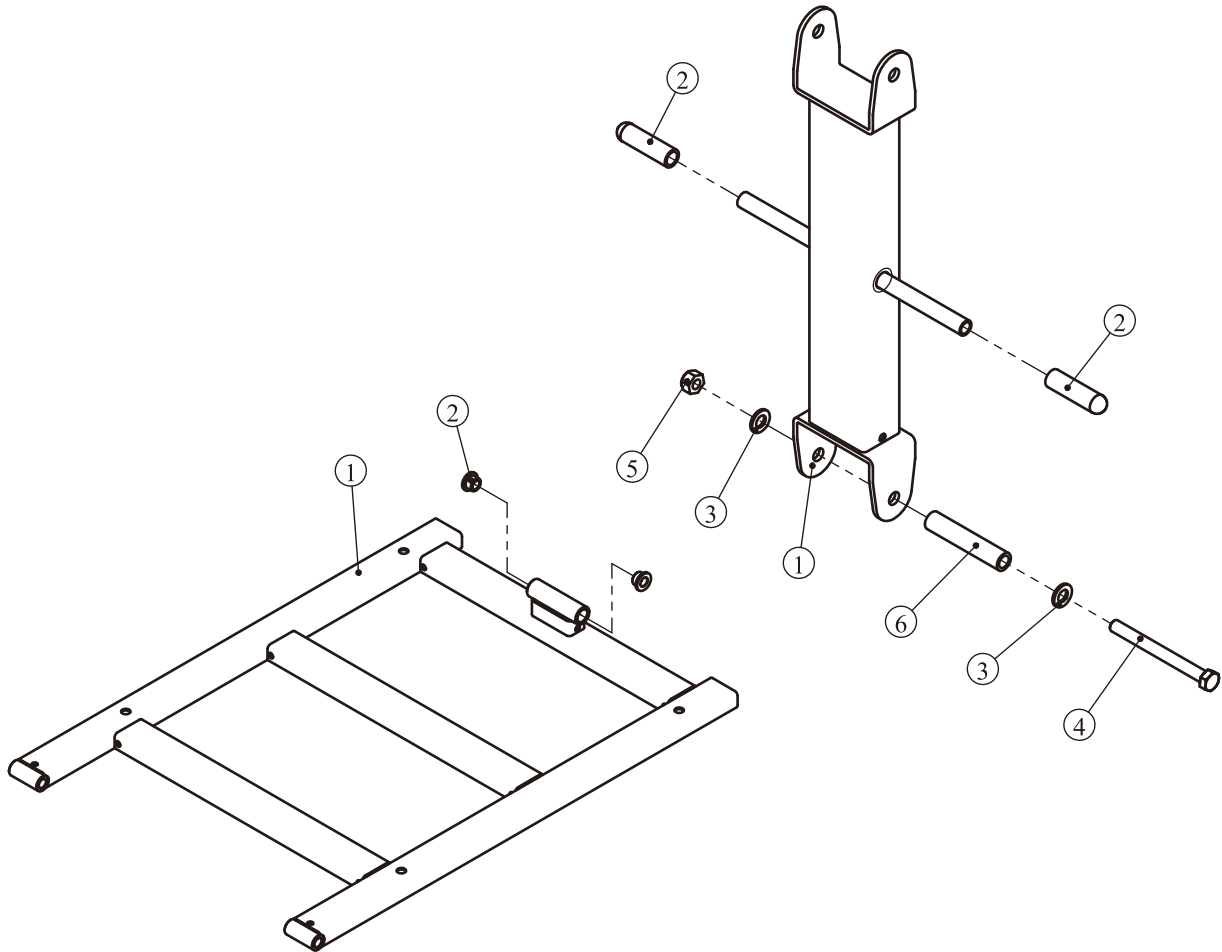

Grade No.	Part No.	Description	QTY
19.1.1	IFP17111300	Bottom Pedal Support Frame	1
19.1.2	M01402000	Barbell Plug Bumper	2

Grade No.	Part No.	Description	QTY
20.1	IFP17111400	Adjustable Back Pad Frame	1
20.2	CG50001700P201C	Adjustable Back Pad Grip	2
20.3	GB9512DHS2	Flat Washer $\Phi 13 * \Phi 24 * 2.5$	2
20.4	GB5780M12*125DHS20	Hex Head Cap Screw M12*125	1
20.5	NM12DHS2	Nylon Lock Nut M12	1
20.6	KPSFID0700	Spacer	1



# Measurement Guide

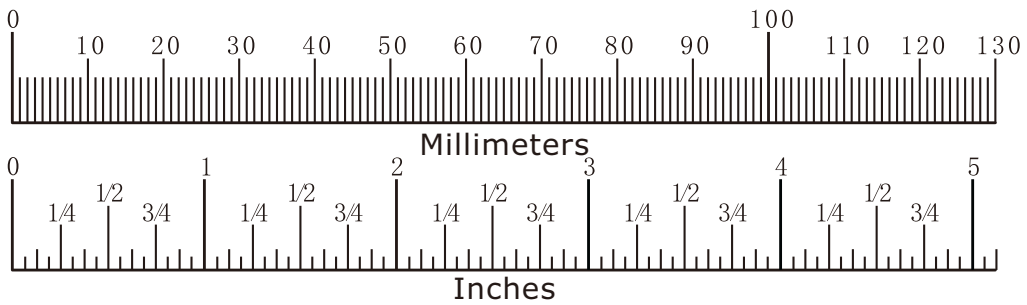
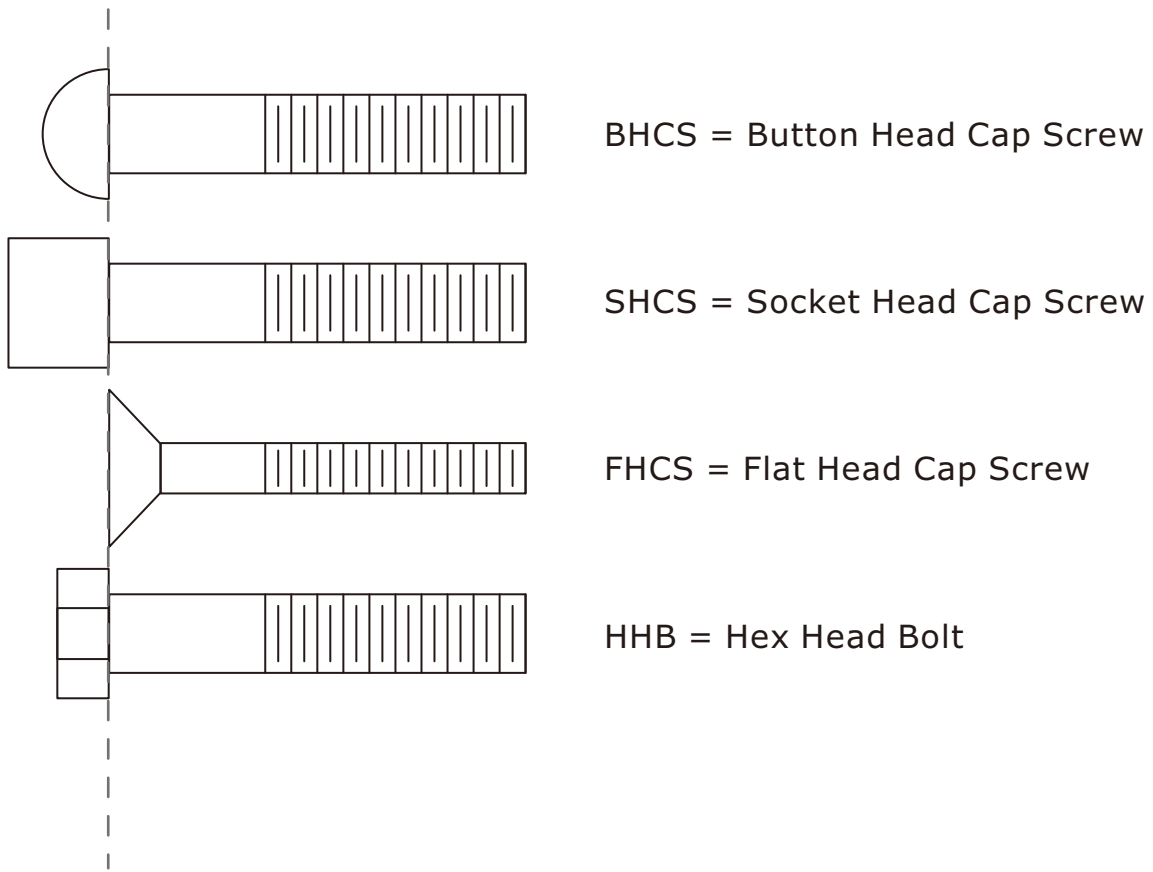

Diameter of bolt (mm/inch)	M6(1/4")	M8(5/16")	M10(3/8")	M12(1/2")	M16(5/8")
Tightening torque (N.m)	9~12	22~30	45~59	78~104	193~257
Operational methods for adult men	The strength of the wrist	The strength of the wrist and forearm	The strength of the entire arm	The strength of the arm and upper body	with all strength

# Assembly Instructions

Assembly of the equipment takes professional installers about 2 hours. If this is the first time you have assembled this type of equipment, plan to spend more time. It is strongly recommended to assemble the equipment by professional installers. You may find it quicker, safer, easier to assemble this equipment with the help of a friend, as some of components may be large, heavy or awkward to handle alone. It is important that you assemble your product in a clean, clear, uncluttered area. This will enable you to move around the product while you are fitting components and reduce the possibility of injury during assembly.

## **NOTE**

As with any assembled part, proper alignment and adjustment is critical. While tightening the fasteners, be sure to leave room for adjustments. Do not fully tighten the fasteners until instructed to do so. Be careful to assemble the components in the sequence presented in this guide.

# Assembly

## STEP 1

1. Attach the Back Upright Frame ASSY (#2) to the Bottom Frame (#3) using:
  - two M10\*100 HHB (#27)
  - four  $\Phi 11*\Phi 20*2$  Flat Washer (#32)
  - two Nylon Lock Nut M10 (#35)
2. Attach the Back Connect Frame ASSY (#1) to the Bottom Frame (#3) using:
  - three M10\*75 HHB (#25)
  - six  $\Phi 11*\Phi 20*2$  Flat Washer (#32)
  - three Nylon Lock Nut M10 (#35)

**Note: DO NOT tighten the hardware.**

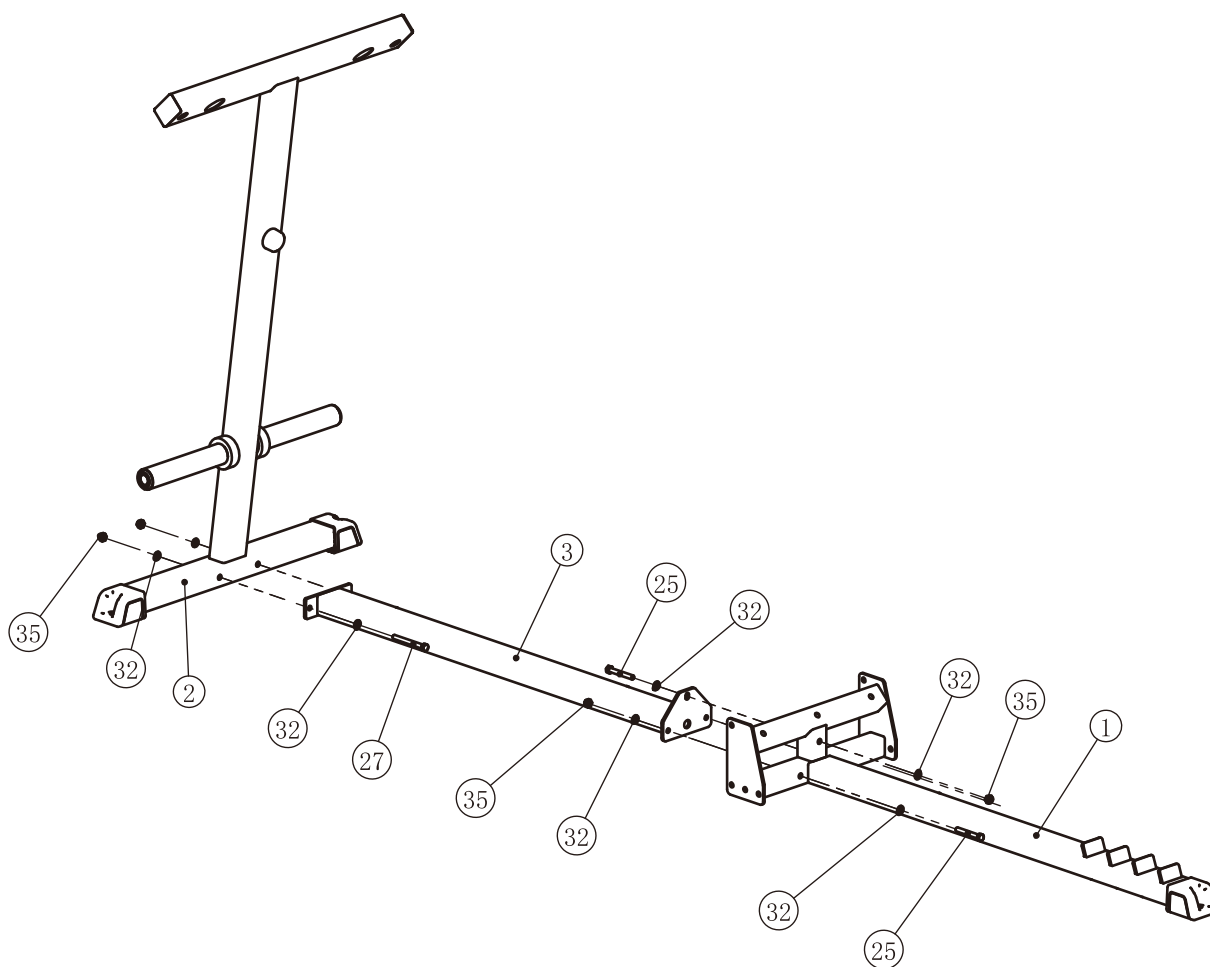

# Assembly

## STEP 2

1. Attach the Right Support Frame ASSY (#13) and the Left Support Frame ASSY (#14) to the Back Connect Frame ASSY (#1) Using:  
six M10\*70 HHB (#26) twelve  $\Phi 11*\Phi 20*2$  Flat Washer (#32)  
six Nylon Lock Nut M10 (#35)
2. Attach the Bottom Pedal Assy II (#19) to the Right Support Frame ASSY (#13) and the Left Support Frame ASSY (#14) Using:  
two M12\*80 HHB (#29) four  $\Phi 13*\Phi 24*2.5$  Flat Washer (#33)  
two Nylon Lock Nut M12 (#36)
3. Attach the Adjustable Back Pad Frame ASSY (#20) to the Bottom Pedal Assy II (#19) Using:  
one M12\*125 HHB (#31) two  $\Phi 13*\Phi 24*2.5$  Flat Washer (#33)  
one Nylon Lock Nut M12 (#36)

**Note: DO NOT tighten the hardware.**

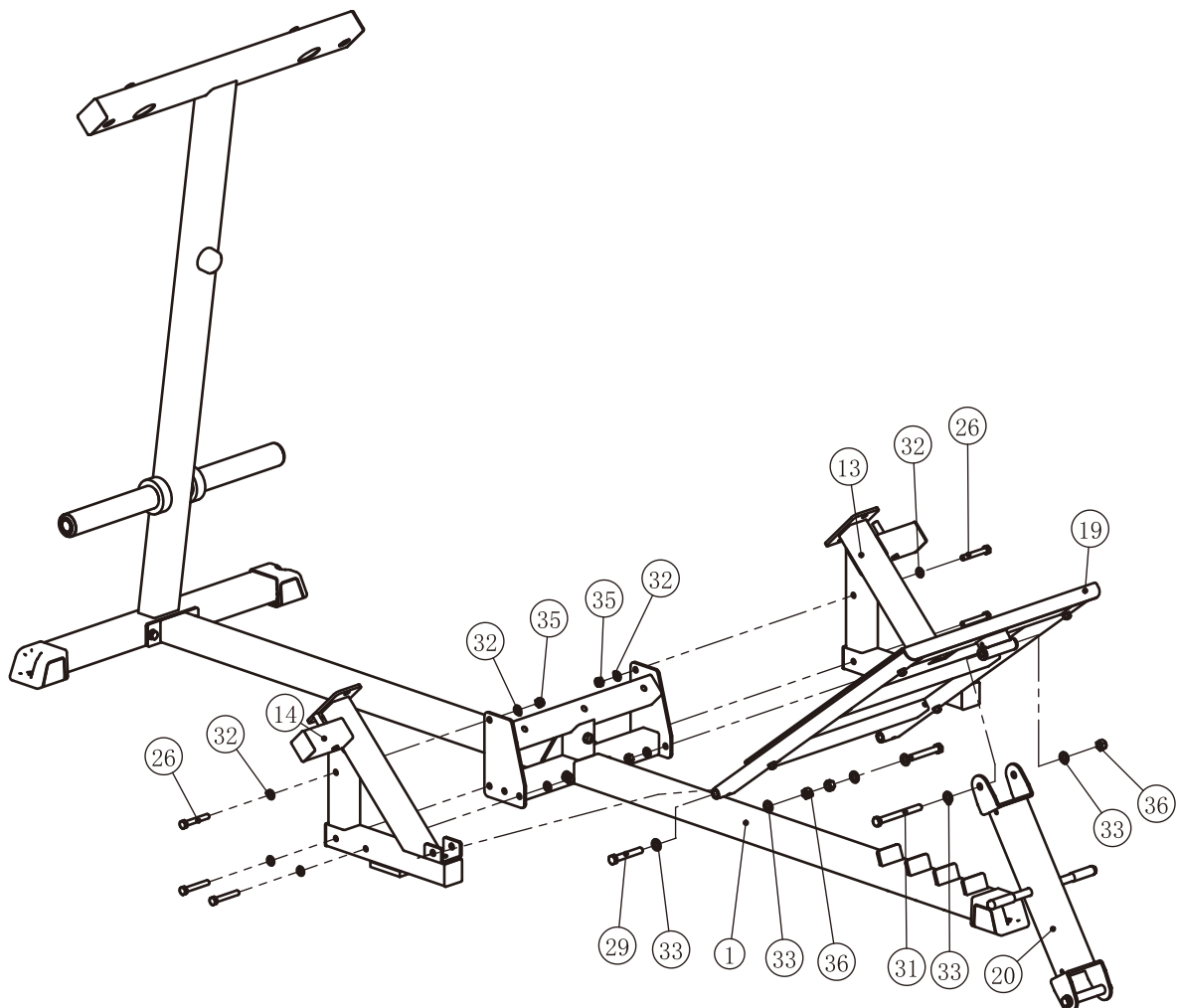

# Assembly

## STEP 3

1. Attach the Carriage ASSY (#15) to the Guide Frame ASSY (#7).
2. Attach two Guide Frame ASSY (#7), one Right Safe Frame ASSY (#5) and one Left Safe Frame ASSY (#6) to the Back Upright Frame ASSY (#2), the Right Support Frame ASSY (#13) and the Left Support Frame ASSY (#14) Using:
  - four M10\*30 HHB (#24)
  - two M12\*30 HHB (#28)
  - eight  $\Phi 11*\Phi 20*2$  Flat Washer (#32)
  - four Nylon Lock Nut M10 (#35)
  - two  $\Phi 10$  Spring Washer (#34)
  - two  $\Phi 13*\Phi 24*2.5$  Flat Washer (#33)

**Note: Wrench Tighten Bolts and Nylon Lock Nuts.**

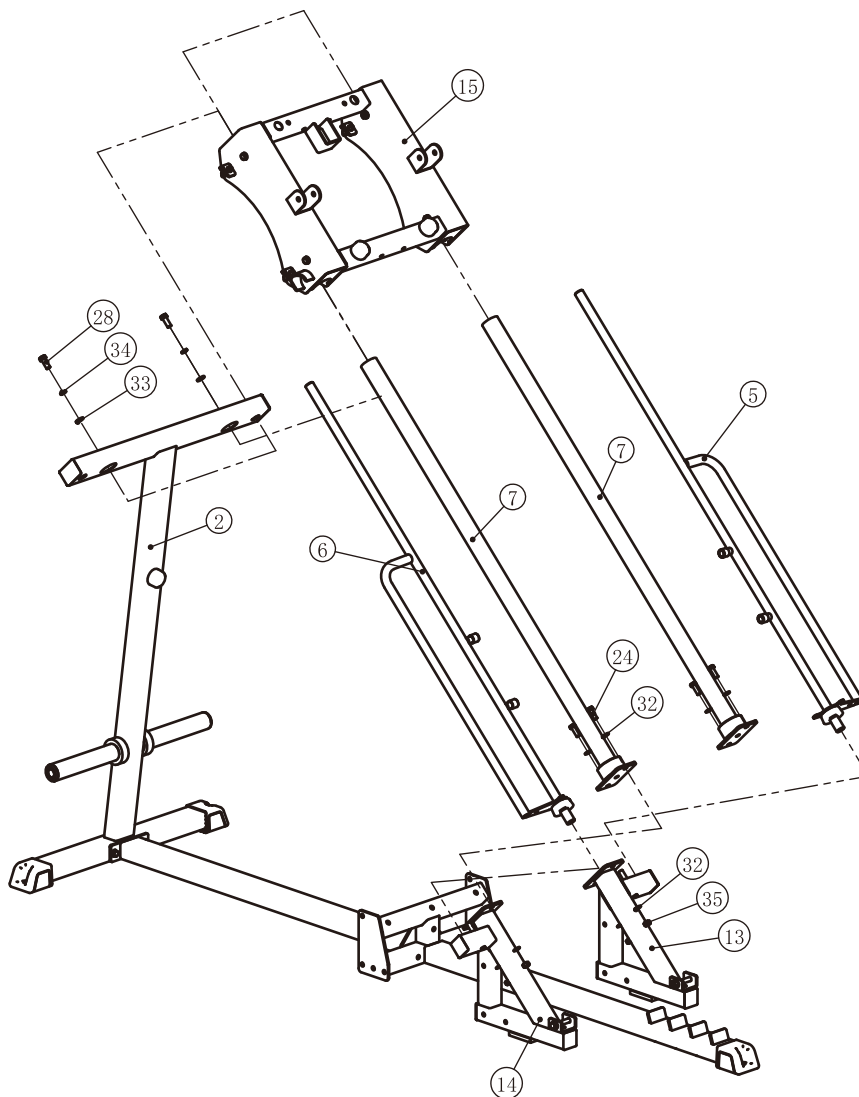

# Assembly

## STEP 4

1. Attach the Adjustable Frame ASSY (#16) and the Barbell Frame ASSY (#4) to the Carriage ASSY (#15) Using:
 

four M10*70 HHB (#26)	twelve $\Phi 11*\Phi 20*2$ Flat Washer (#32)
six Nylon Lock Nut M10 (#35)	two M10*75 HHB (#25)
2. Attach the Shoulder Handle Frame ASSY (#17) to the Carriage ASSY (#15) Using:
 

two M10*75 HHB (#25)	six $\Phi 11*\Phi 20*2$ Flat Washer (#32)
two Nylon Lock Nut M10 (#35)	two M10*20 HHB (#22)
3. Attach the Upper Pedal ASSY (#18) to the Carriage ASSY (#15) Using:
 

two M12*85 HHB (#30)	four $\Phi 13*\Phi 24*2.5$ Flat Washer (#33)
two Nylon Lock Nut M12 (#36)	

**Note: Wrench Tighten Bolts and Nylon Lock Nuts.**

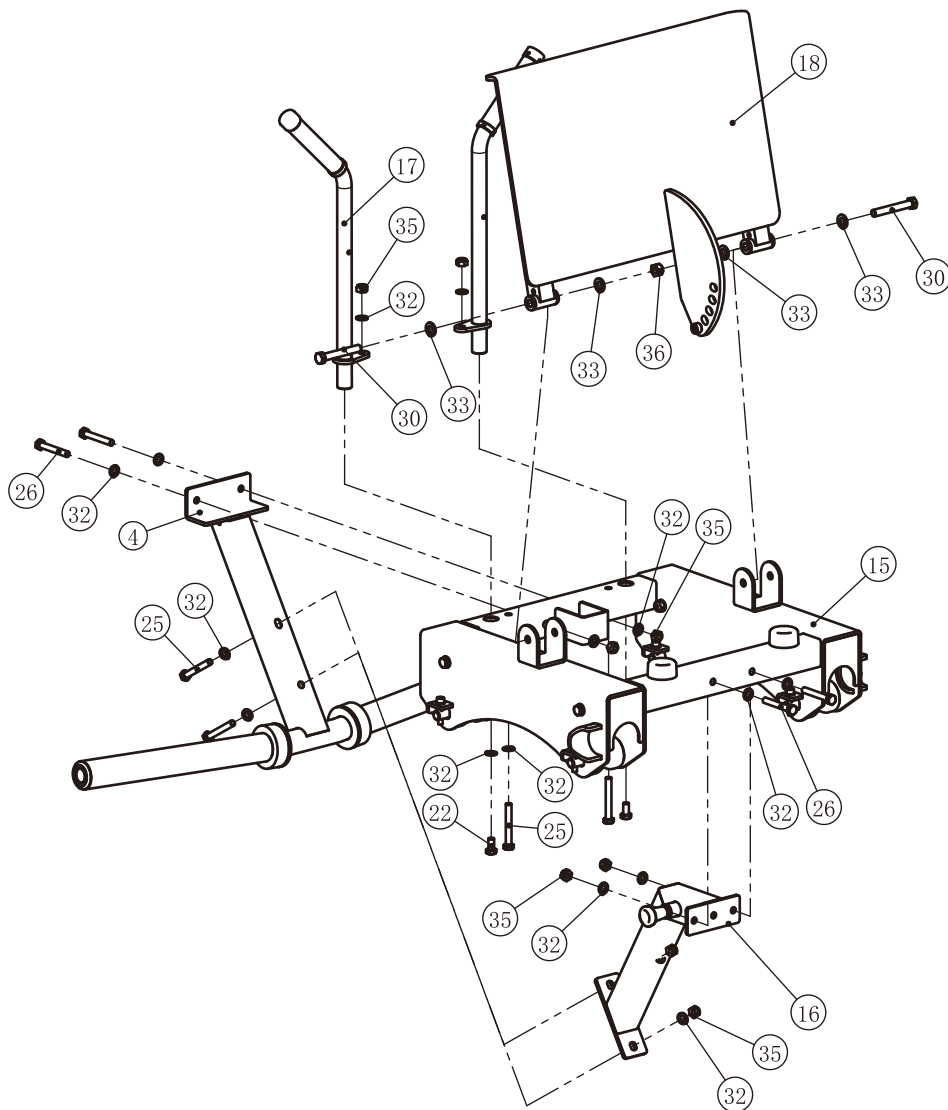

# Assembly

## STEP 5

1. Attach the Back Pad ASSY (#12) to the Bottom Pedal ASSY II (#19).
2. Attach two Shoulder Pad (#10) and two Pad bracket (#9) to two Shoulder Handle Frame ASSY (#17) Using:
 

two M6*15 HHB (#21)	eight $\Phi 11*\Phi 20*2$ Flat Washer (#32)
eight M10*20 HHB (#22)	
3. Attach the Seat pad (#11) to the Back Connect Frame ASSY (#1) Using:
 

two M10*70 HHB (#26)	two $\Phi 11*\Phi 20*2$ Flat Washer (#32)
----------------------	---
4. Attach two Handle Frame ASSY (#8) to the Right Safe Frame ASSY (#5) and the Left Safe Frame ASSY (#6) Using:
 

two M10*25 HHB (#23)	four $\Phi 11*\Phi 20*2$ Flat Washer (#32)
two Nylon Lock Nut M10 (#35)	

**Note: Wrench Tighten Bolts and Nylon Lock Nuts.**

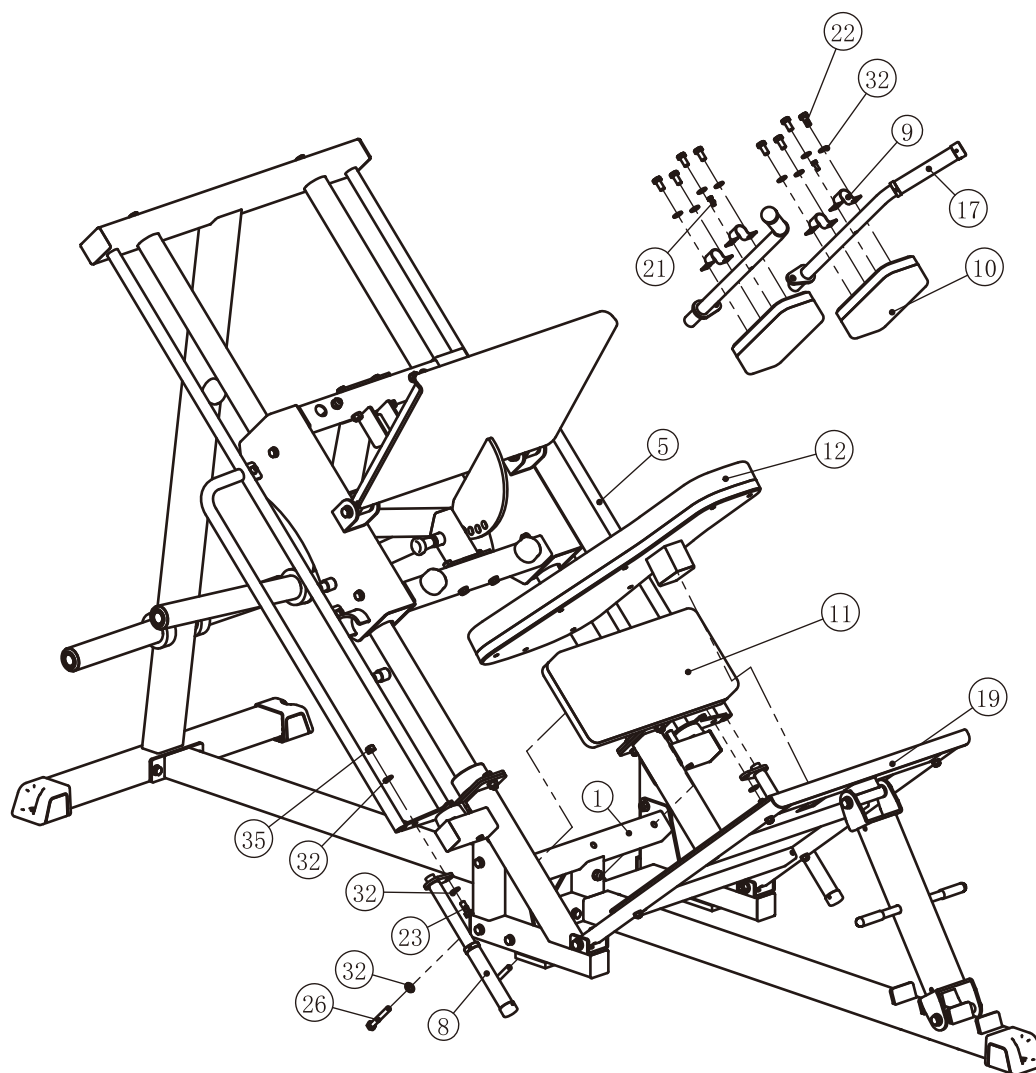

# Assembly

## STEP 6

Back Pad ASSY (#12) can be used in one of two ways.

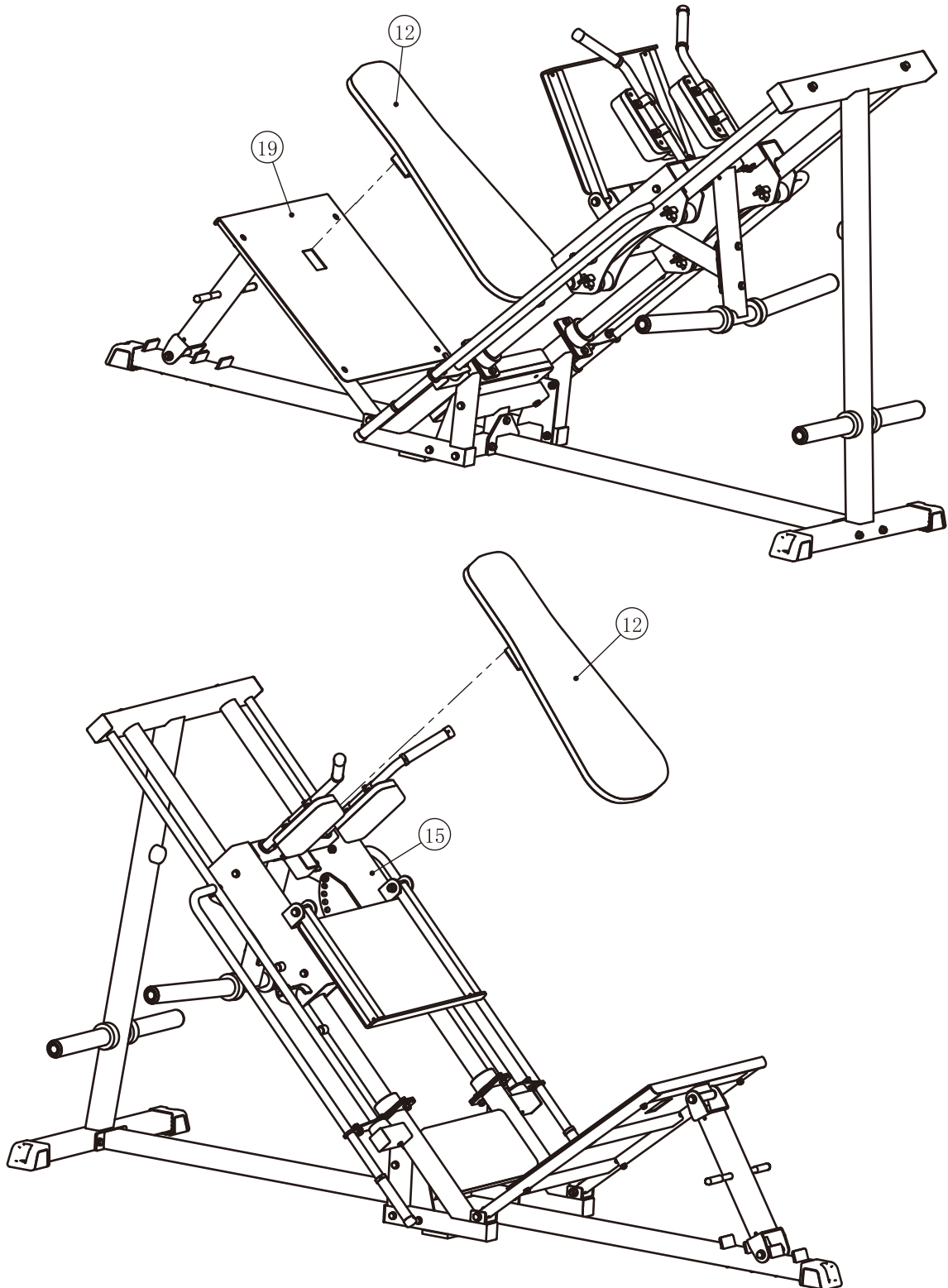



# Adjust and Exercise Instruction

## Exercise Instructions

### Leg Press

1. Select an appropriate weight.
2. Seated and push Upper Pedal ASSY forward then converge the Safe Frame ASSY.
3. Push Upper Pedal ASSY forward until legs almost straight.
4. Pause slightly then slowly return to the starting position.
5. Before finished, put Safe Frame ASSY back while legs straight.

### Hack Squat

1. Select an appropriate weight.
2. Lean on Back Pad and push Shoulder Pad up then converge the Safe Frame ASSY.
3. Push Shoulder Pad up until legs almost straight.
4. Pause slightly then slowly return to the starting position.
5. Before finished, put Safe Frame ASSY back while legs straight.

### Weight Plate Installation Requirements

1. Please use Olympic Weight Plate which hole is greater than  $\Phi 50\text{mm}$  and external diameter is less than  $\Phi 500\text{mm}$ .
2. The total weight of one side can not be greater than 175kg.
3. This equipment does not contains Weight Plate.

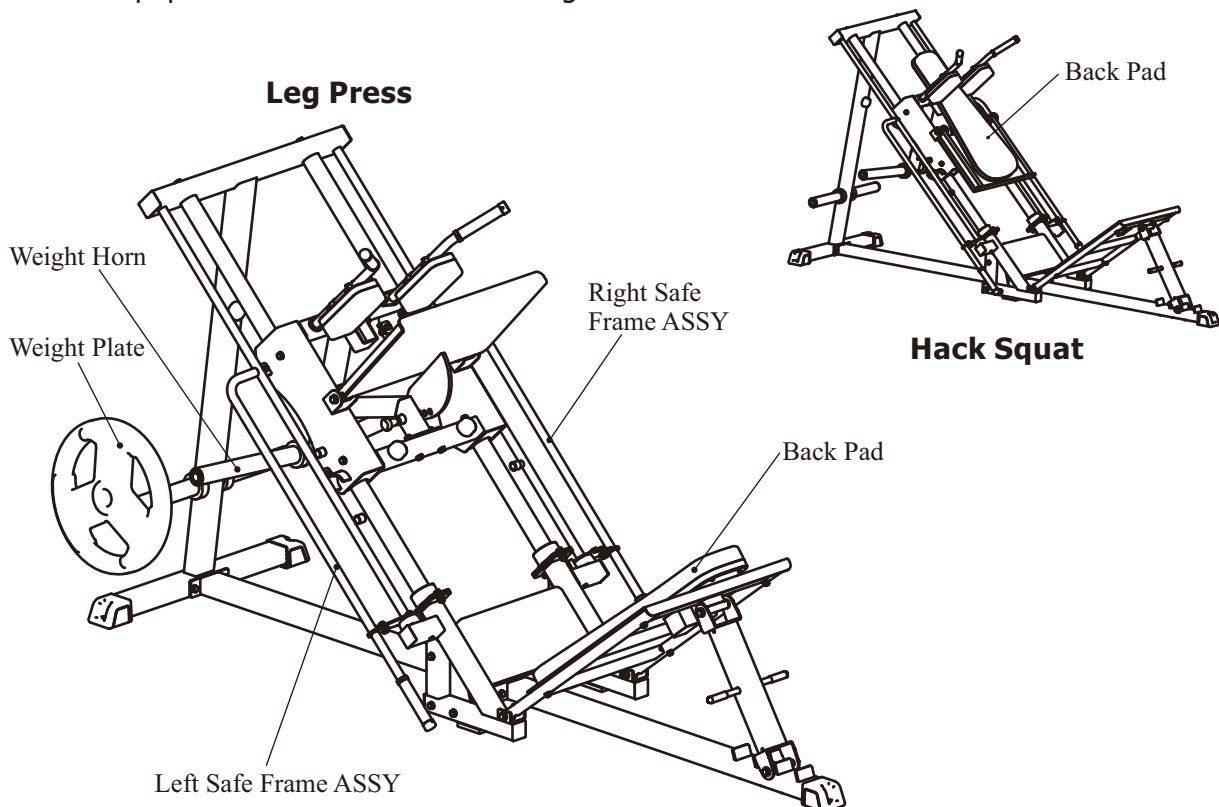

# Adjust and Exercise Instruction

## Function adjustment

### Leg Press

1. Pull the Adjustable Back Pad Frame ASSY then Adjust Bottom Pedal ASSY II to desired position.
2. Put Back Pad on the Bottom Pedal ASSY II as shown.

### Hack Squat

1. Pull the Pull Pin then put Upper Pedal ASSY down.
2. Put Back Pad on the Upper Pedal ASSY as shown.

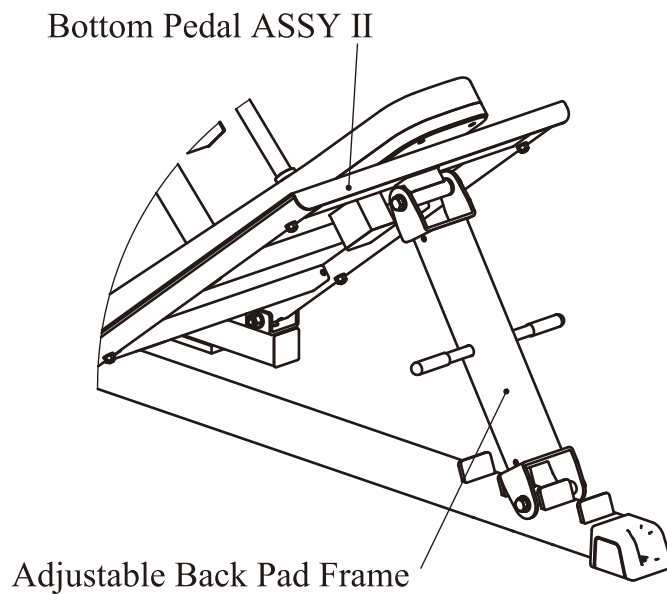
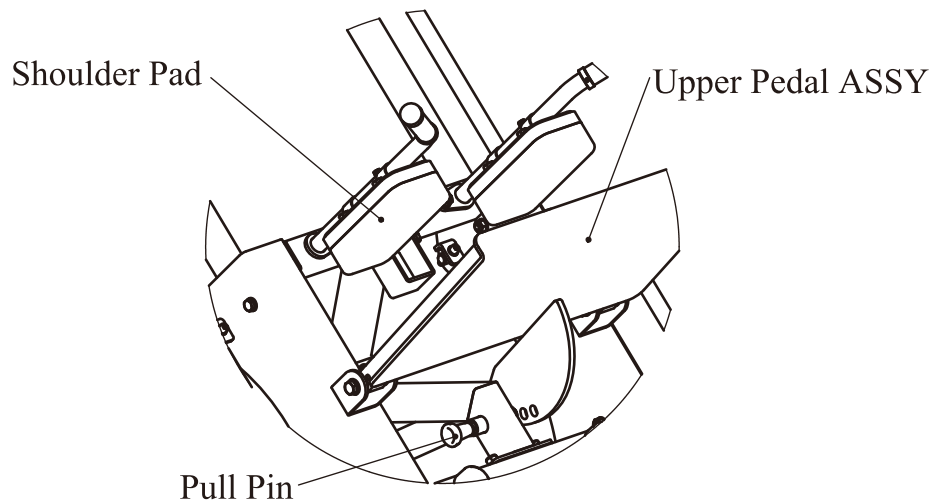

# Maintenance Schedule

ROUTINE	COMMERCIAL MAINTENANCE	HOME MAINTENANCE	LATEST DATE ENTRY					
Inspect; Links, Pull Pins, Snap Locks, Swivels, Weight Stack Pins	DAILY	WEEKLY						
Clean; Upholstery	DAILY	WEEKLY						
Inspect; Cables or Belts and their tension	DAILY	WEEKLY						
Inspect; Accessory Bars, and Handles	WEEKLY	3 MONTHS						
Inspect; All Decals	WEEKLY	3 MONTHS						
Inspect; All Nuts and Bolts, Tighten if needed	WEEKLY	3 MONTHS						
Inspect; Anti-Skid Surface	WEEKLY	3 MONTHS						
Clean & Lubricate; Guide Rods with a Teflon (PTFE) based lubricant (Superlube)	MONTHLY	3 MONTHS						
Lubricate; Seat Sleeves, Turcite Bushings, Linear Bearing	MONTHLY	3 MONTHS						
Clean and Wax; All Glossy Finishes	6 MONTHS	YEARLY						
Repack with Grease; Linear Bearings	6 MONTHS	YEARLY						
Replace; Cables, Belts and Connecting Parts	YEARLY	3 YEARS						

*Your equipment comes with a commercial maintenance decal. For personal, in home use, please follow the home maintenance schedule listed above.*

# General Maintenance Information

## **Links, Pull-Pins, Snap Hooks, Swivels, Weight Stack Pins:**

- \* Check all pieces for signs of visible wear or damage.
- \* Check springs in snap hooks and pull-pins for proper tension and alignment.
- \* If the spring sticks or has lost its rigidity, replace it immediately.

## **Upholstery:**

- \* To ensure prolonged upholstery life and proper hygiene, all upholstered pads should be wiped down with a damp cloth after every workout.
- \* Periodically take the time to use a mild soap or an approved vinyl upholstery cleaner to deter the onset of cracking or drying. Avoid using any abrasive cleaners or cleaners not intended for use on vinyl.
- \* Replace ripped or worn upholstery immediately.
- \* Keep sharp or pointed objects clear of all upholstery.

## **Decals:**

- \* Inspect and familiarize yourself with any safety warnings or other user information posted on each decal.

## **Nuts and Bolts:**

- \* Inspect all nuts and bolts for any loosening and tighten if needed.
- \* Go through a re-tightening sequence periodically to ensure that all hardware is tensioned proper.

## **Anti-Skid Surfaces:**

- \* These surfaces are designed to supply secure footing and need to be replaced if they appear worn or become slippery.

## **Belts and Cables:**

- \* We use only high quality belt, and mil-spec cables.
- \* Visually inspect the belts and cables for fraying, cracking, peeling or discoloration.
- \* While the machine is not in use, carefully run your fingers along the belt or cable to feel for thinning or bulging areas.
- \* Replace belts and cables immediately at the first signs of damage or wear. Do not use equipment until belts or cables have been replaced.

## **Belt and Cable Tension:**

- \* Referring to the Owners Manual, when belts or cables are used check all bolts attachments to be sure they are properly attached.
- \* Check slack in cables and re-adjust cable tension if needed.

## **Seat Sleeves, Guide Rods:**

- \* Wipe down adjusting tubes with a dust free rag before applying lubricant.
- \* Lubricate seat sleeves and Guide Rods with a Silicon or Teflon based lubricant spray.

## **Linear Bearings:**

- \* Referring to the Owners Manual carefully disassemble the bearing from its housing and place a finger full of light grease (lithium, super lube, etc.) into the inside of the bearing. Using your finger, press the grease into the ball-bearings and their tracks. Repeat until the ball-bearing tracks are full of grease. Insert the shaft back into the bearing and wipe off excess grease.

**PLEASE KEEP THIS FOR YOUR RECORDS**

# Weight Training Tips

Use this manual to guide you through the basic exercises you can perform on your equipment. To gain maximum results and avoid possible injury, consult a fitness professional to develop your complete exercise program.

Always consult your physician before starting any exercise program.

To be successful in your exercise program, it is important to develop an understanding of the basic principles of strength training. Now that you have your equipment, it is only natural that you want to get started immediately. First, determine a set of realistic goals and objectives for yourself. By deciding on an exercise plan that is right for you prior to starting, you will contribute significantly to your success.

Warm up properly before engaging in weight resistance training. Stretching, yoga, jogging, calisthenics or other cardiovascular exercise can help prepare your body for the heavier workload of lifting weights.

Learn how to perform the exercise correctly before using heavy weight. Correct form is important to avoid injury and to ensure that you work the proper muscle groups.

Know your limitations. If you are new to weight training or are embarking on an exercise regimen after a long layoff, start slowly and build foundational strength over a longer period of time.

Pay attention to your breathing. Exhale when you exert is a general rule of thumb. Never hold your breath.



**bodytone**



[bodytone.eu](http://bodytone.eu)