

# ***BODYTONE***

## **FORZABOLD** **FB51**

GLUTE



## **OWNER'S MANUAL**

**!CAUTION!**

Read all precautions and instructions in this manual before using this equipment.

# Table Of Contents

## CAUTION!

Read all precautions and instructions in this manual before using this equipment.

Important Safety Instructions-----	3
Instructions-----	5
Exploded View and Parts List-----	6
Measurement Guide-----	14
Assembly Instructions-----	15
Assembly-----	16
Adjust Instructions and Exercise Instructions-----	26
Maintenance Schedule-----	27
General Maintenance Information-----	28
Weight Training Tips-----	29

Please assemble according to the actual **Weights** you buy !

---

# Important Safety Instructions

Before beginning any fitness program, you should obtain a complete physical examination from your physician. When using exercise equipment, basic precautions should always be taken, including the following:

1. Read all instructions before using the equipment.  
These instructions are written to ensure your safety and to protect the unit.
2. Use the equipment only for its intended purpose as described in this guide.  
Do not use accessory attachments that are not recommended by the manufacturer: such attachments might cause injuries.
3. The product should only be used on a level surface and is with 0.6 meters space around the product.  
Do not use the equipment outdoors.
4. Do not allow children on or near the equipment. And children are not allowed to use this equipment.  
Teenagers should use this equipment with adult supervision.
5. Do not overexert yourself or work to exhaustion.  
Do not attempt to lift more weight than you can control safely.  
If you feel any pain or abnormal symptoms, stop your workout immediately and consult your physician.
6. This equipment is not used as medical apparatus and instruments.
7. Never operate the unit when it has been dropped or damaged.  
Never drop or insert anything into any opening in the equipment.  
Always check the unit and its cables before each use. Make sure that all fasteners and cables are secure and in good working condition.  
Frayed or worn cables can be dangerous and may cause injury. Periodically check these cables for any indication of wear.  
Keep hands, limbs, loose clothing and long hair well out of the way of moving parts.
8. Be careful when getting on or off the equipment.
9. Wear proper exercise clothing and shoes for your workout, no loose clothing.

# Important Safety Instructions

## Personal Safety During Assembly

Read each step in the assembly instructions and follow the steps in sequence. Do not skip ahead. If you skip ahead, you may learn later that you have to disassemble components and that you may have damaged the equipment.

Assemble and operate the equipment on a solid, level surface. Locate the unit a few feet from walls or furniture to provide easy access. The equipment is designed for your enjoyment. By following these precautions and using common sense, you will have many safe and pleasurable hours of healthful exercise with the equipment.

## Training Area and Free Area

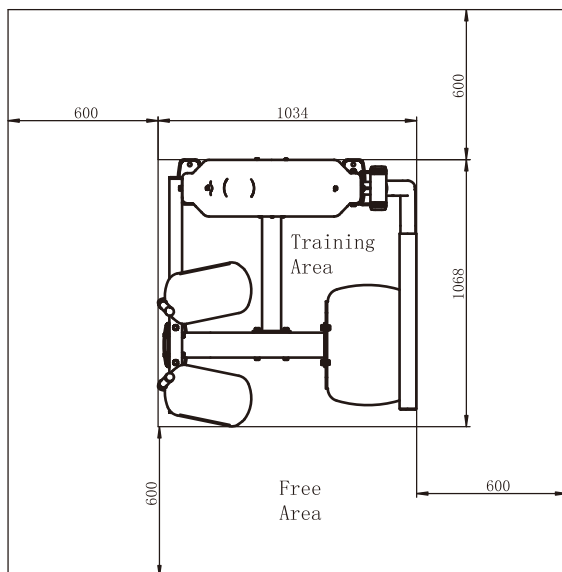

## Specifications

Class: S

Maximum Wt. Capacity: 134kg/ 295lbs

Maximum User Weight: 150kg/ 330lbs

Product Dimension: 1034\*1068\*1504mm

Product Total Surface: 1139\*1068mm

Product Total Mass:

# Instructions

Before beginning assembly please take the time to read instructions thoroughly. Please use the various lists in this manual to make sure that all parts have been included in your shipment. When ordering, use part number and description from the lists. Use only our replacement part when servicing. Failure to do so will void your warranty and could result in personal injury.

The equipment is designed to provide the smoothest, most effective exercise motion possible. After assembly, you should check all functions to ensure correct operation. If you experience problems, first recheck the assembly instructions to locate any possible errors made during assembly. If you are unable to correct the problem, call your authorized dealer. Be sure to have your serial number and this manual when calling. When all parts have been accounted for, continue on.

## Tools Required

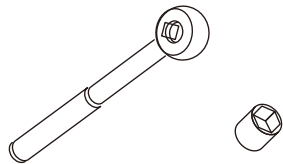

Ratchet Wrench and Socket

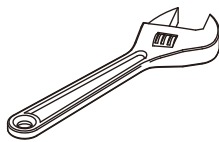

Adjustable Wrench

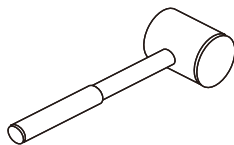

Rubber Mallet

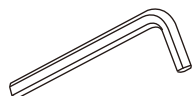

Hex Key Wrench Set

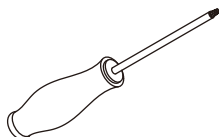

Phillips Screwdriver

# Exploded View and Parts List

## Overall

Item No.	Grade No.	Part No.	Description	QTY
1	1	FB5101ASSY	Weight Stack Frame ASSY	1
2	2	IT95014200	Top Plate	1
3	3	IT95014400	Guide Rod $\Phi 19*1242$	2
4	4	IF9301B21ASSY	Front Bracket ASSY	1
5	5	FB013100	Top Cover	1
6	6	FB013400	Spout Plug	1
7	7	FB0135ASSY	Left Bracket ASSY	1
8	8	FB0136ASSY	Right Bracket ASSY	1
9	9	FB0137ASSY	Bottom Bracket ASSY	1
10	10	IF932602ASSY	Main Frame ASSY	1
11	11	IF932603ASSY	Swing Frame ASSY	1
12	12	IF932604ASSY	Arm Frame ASSY	1
13	13	IF932605ASSY	Limit frame ASSY	1
14	14	IF932606ASSY	Foot Frame ASSY	1
15	15	IF93260700	Connecting seat	1
16	16	IF93260800	Bottom Cross Brace	1
17	17	IF93265600	Tension Cable ASSY	1
18	18	SG500110400V5	4.5" Pulley	3
19	19	IF93012600	Axis $\Phi 25*133*M10$	1
20	20	IF93262000	Cable Keeper	1
21	21	FB2332ASSY	Front Shroud ASSY	1
22	22	FB013300	Rear Shroud	1
23	23	IT95261200V2	Arm Pad	2

# Exploded View and Parts List

## Overall

Item No.	Grade No.	Part No.	Description	QTY
24	24	IT90012000V1P201C	Selector Pin W/Coil	1
25	25	FE97211900	Cap $\Phi 60$	2
26	26	FE97212000	Circle Ring $\Phi 62.5 \times 5$	2
27	27	IT80023000	Weight Rubber Bumper	2
28	28	IT95016100	Guide Rod Fixing Sleeve $\Phi 25 \times \Phi 19 \times 45$	2
29	29	HFOPT900-04A0602	Spring $\Phi 15.5 \times \Phi 1.5 \times 36$	2
30	30	GB9510DS2	Flat Washer $\Phi 11 \times \Phi 20 \times 2$	40
31	31	GB818M6*20DHS2	Cross Recessed Pan Head Screw M6*20	12
32	32	GB9074ST4.2*16DHS	Cross Disc Self Tapping Screw ST4.2*16	12
33	33	NM10DS2	Nylon Lock Nut M10	15
34	34	GB9310DS12	Spring Washer $\Phi 10$	6
35	35	GB70M10*25DS20NL	Socket Head Cap Screw M10*25	2
36	36	GB5780M10*50DS20	Hex Head Bolt M10*50	3
37	37	GB5780M10*75DS20	Hex Head Bolt M10*75	4
38	38	GB5780M10*140DS20	Hex Head Bolt M10*140	2
39	39	GB5781M10*30DS20	Hex Head Bolt M10*30	10
40	40	GB5780M10*120DS20	Hex Head Bolt M10*120	2
41	41	GB5780M10*100DS20	Hex Head Bolt M10*100	2
42	42	GB5781M10*25DS20	Hex Head Bolt M10*25	2
43	43	IF93062200	Washer $\Phi 62 \times \Phi 10.5 \times 3$	2
44	44	NBS8DHS	Hex Key S=8	1
45	45	LW200BS	Wrench $\Phi 6 \times 117$	1
46	46	YHY	Lube	1

# Exploded View and Parts List

## Overall

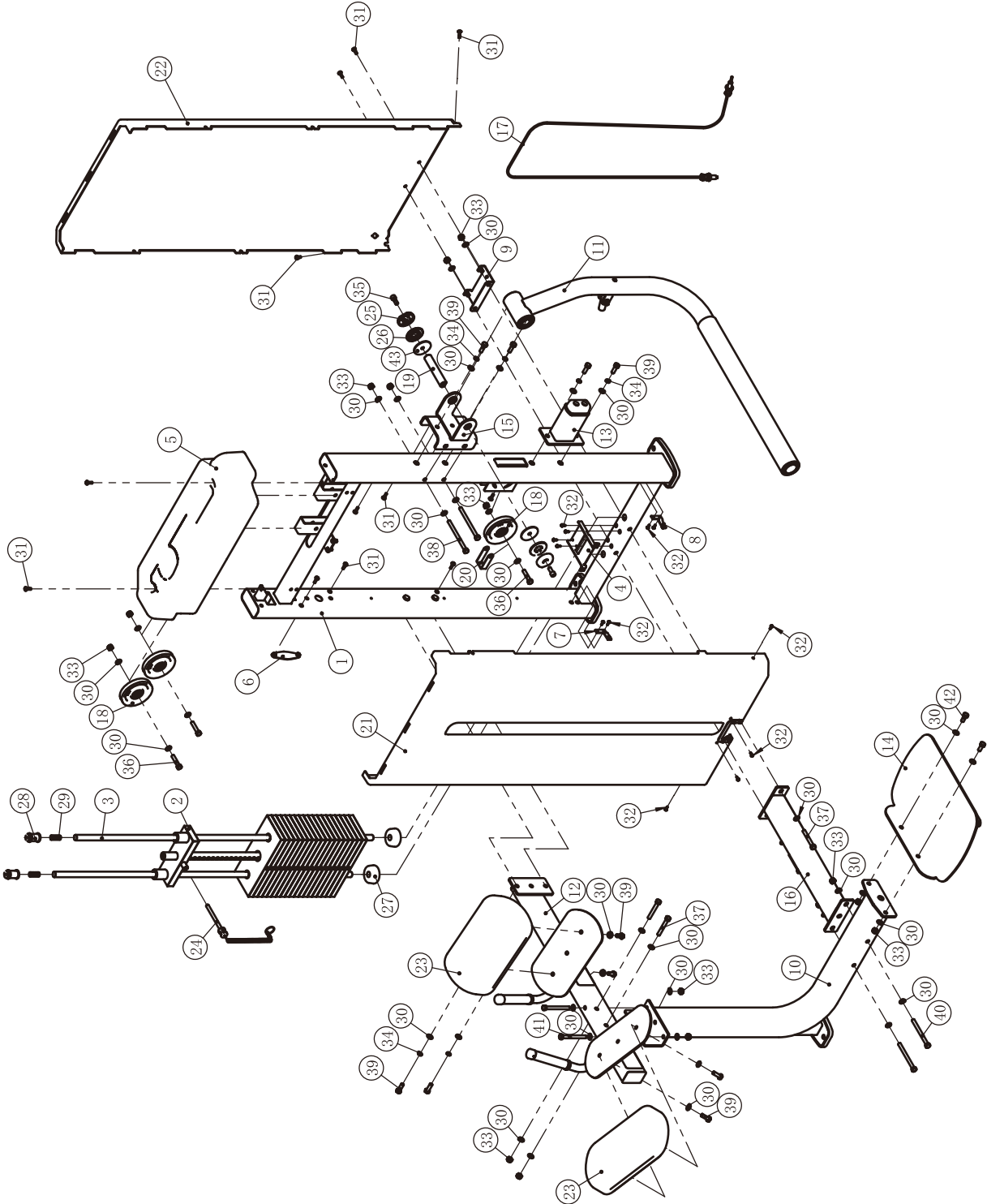



# Exploded View and Parts List

## Weight Stack Frame ASSY

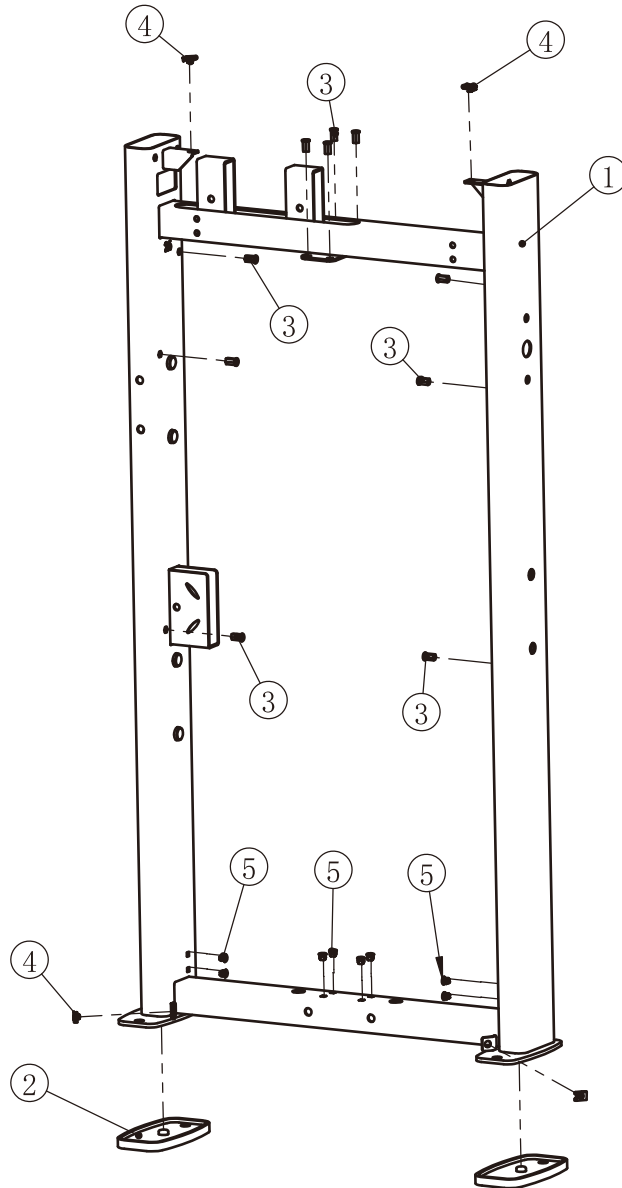

Item No.	Grade No.	Part No.	Description	QTY
1	1.1	IF9326ZN0100	Weight Stack Frame	1
2	1.2	BS81223100	Foot Plate	2
3	1.3	GB17880.5M6*16.5DS17	Rivet Nut M6	10
4	1.4	AC32705800	U-nut M6	4
5	1.5	ECU7P3500	Plastic Nut	8

# Exploded View and Parts List

## Main Frame ASSY

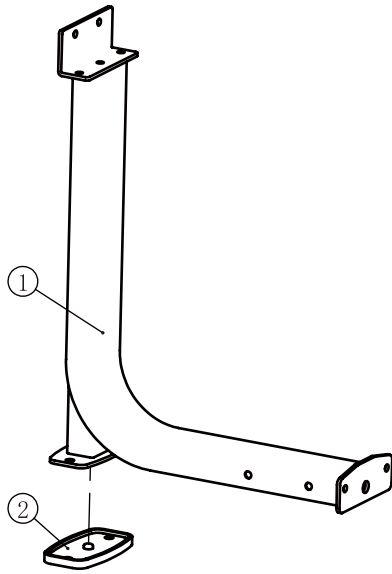

## Swing Frame ASSY

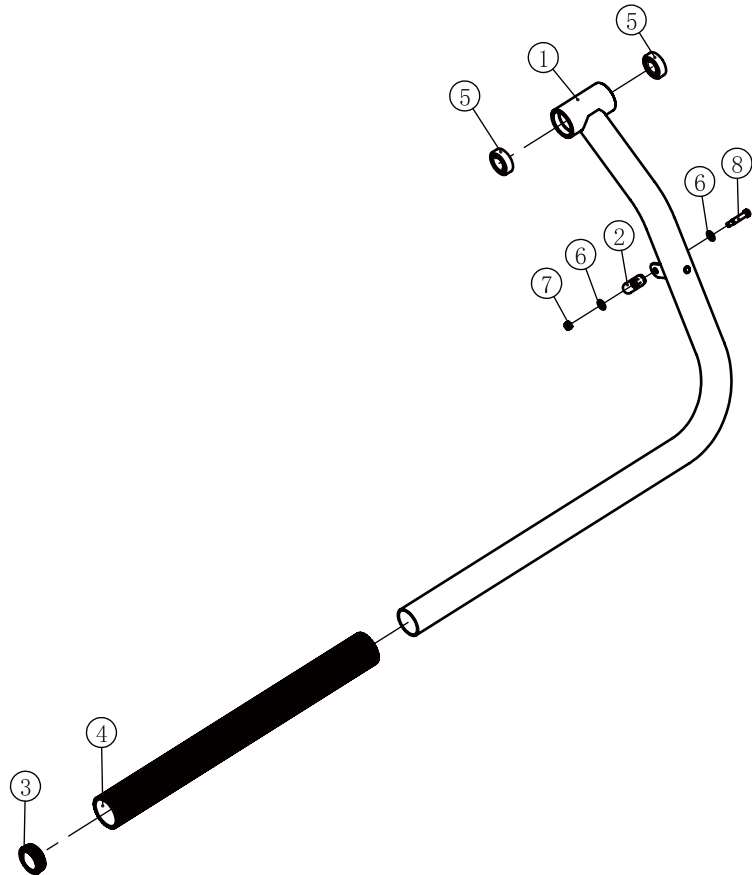

ItemNo.	Grade No.	Part No.	Description	QTY
1	11.1	IF93260200	Main Frame	1
2	11.2	BS81223100	Foot Plate	1

ItemNo.	Grade No.	Part No.	Description	QTY
1	12.1	IF93260300	Swing Frame	1
2	12.2	IF930127ASSY	Cable Connector ASSY	1
3	12.3	PBF40014	Plug $\Phi 60$	1
4	12.4	IT90262300V1	Rubber cover	1
5	12.5	GB2766205-2ZC3	Deep Groove Ball Bearing $\Phi 25*\Phi 52*15$	2
6	12.6	GB9510DS2	Flat Washer $\Phi 11*\Phi 20*2$	2
7	12.7	NM8DS2	Nylon Lock Nut M8	1
8	12.8	IF81105500V1	Cable Retaining Bolt	1

# Exploded View and Parts List

## Cable Connector ASSY

## Arm Frame ASSY

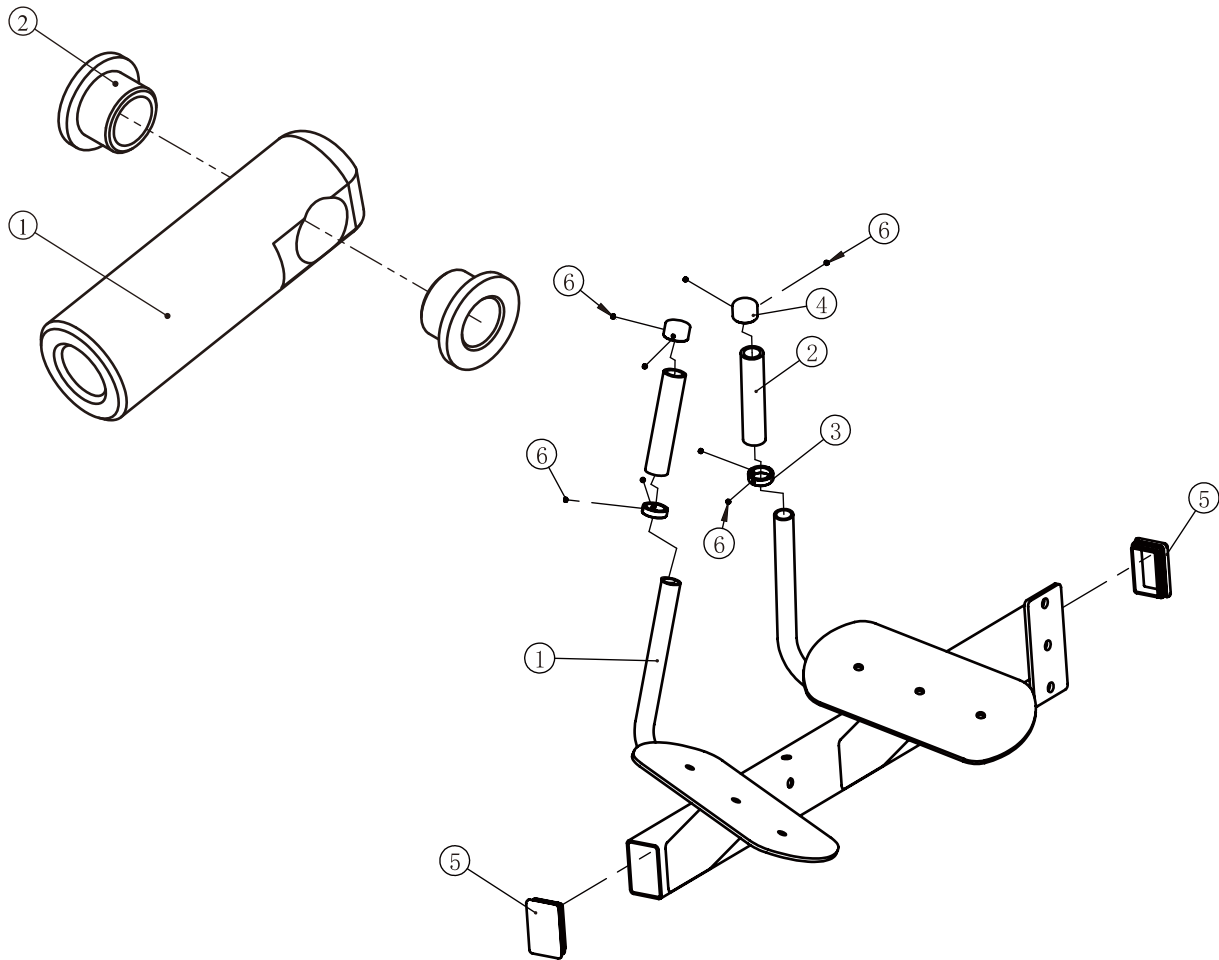

ItemNo.	Grade No.	Part No.	Description	QTY
1	12.2.1	IF93012700	Cable Connector	1
2	12.2.2	BNH0738	Bush $\Phi 18^* \Phi 12.7^* \Phi 9.5^* 9.5$	2

ItemNo.	Grade No.	Part No.	Description	QTY
1	13.1	IF93260400	Arm Frame	1
2	13.2	FE97031800	Grip ST $\Phi 30^* \Phi 22^* 140$	2
3	13.3	V39500	Aluminum Grip Ring $\Phi 25.4$	2
4	13.4	V39600	Aluminum Grip Cap $\Phi 25.4$	2
5	13.5	KPSFID2800	Plug $\square 50.8^* 76.2$	2
6	13.6	YZGB7710-32*3.2N19	Socket Set Screw 10-32UNF*3.2	8

# Exploded View and Parts List

## Limit frame ASSY

## Foot Frame ASSY

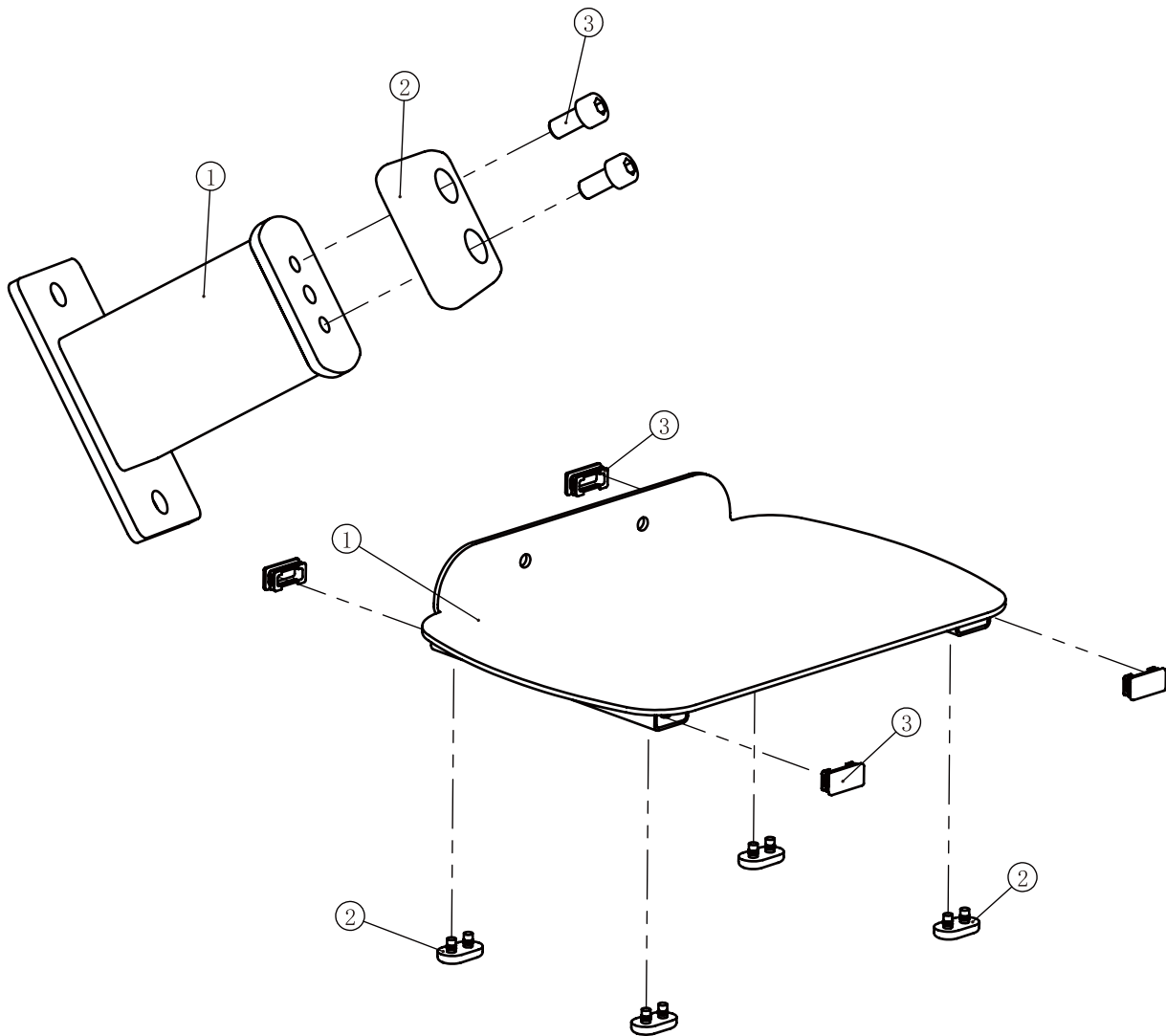

ItemNo.	Grade No.	Part No.	Description	QTY
1	14.1	IF93260500	Limit frame	1
2	14.2	RS17000400	Bumper	1
3	14.3	GB70M10*20DS20	Socket Head Cap Screw M10*20	2

ItemNo.	Grade No.	Part No.	Description	QTY
1	15.1	IF93260600	Foot Frame	1
2	15.2	BG10004600V1	Bumper 44.5*25*8	4
3	15.3	PBF30030	Plug □20*40	4

# Exploded View and Parts List

## Left Bracket ASSY

7

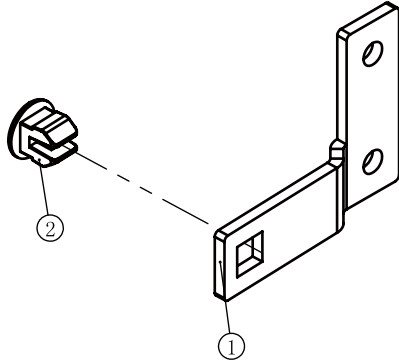

## Right Bracket ASSY

8

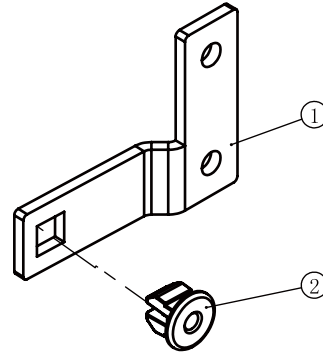

## Bottom Bracket ASSY

9

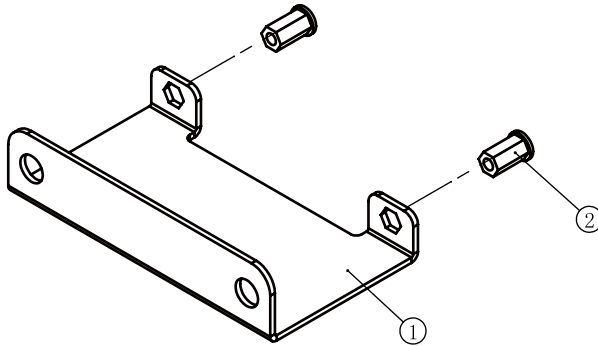

## Front Bracket ASSY

4

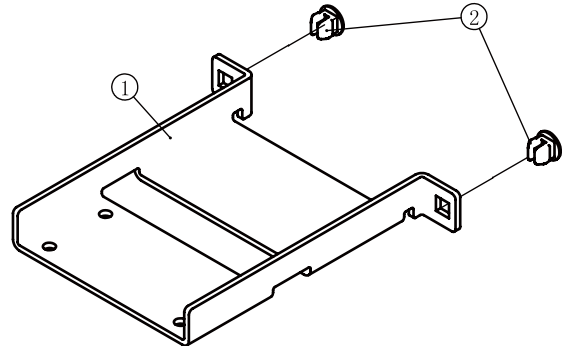

Item No.	Grade No.	Part No.	Description	QTY
1	7.1	FB013500	Left Bracket	1
2	7.2	ECU7P3500	Plastic Nut	1

Item No.	Grade No.	Part No.	Description	QTY
1	8.1	FB013600	Right Bracket	1
2	8.2	ECU7P3500	Plastic Nut	1

Item No.	Grade No.	Part No.	Description	QTY
1	9.1	FB013700	Bottom Bracket	1
2	9.2	GB17880.5M6*16.5DS17	Rivet Nut M6	2

Item No.	Grade No.	Part No.	Description	QTY
1	4.1	IF9301B21.00	Front Bracket	1
2	4.2	ECU7P3500	Plastic Nut	2

# Measurement Guide

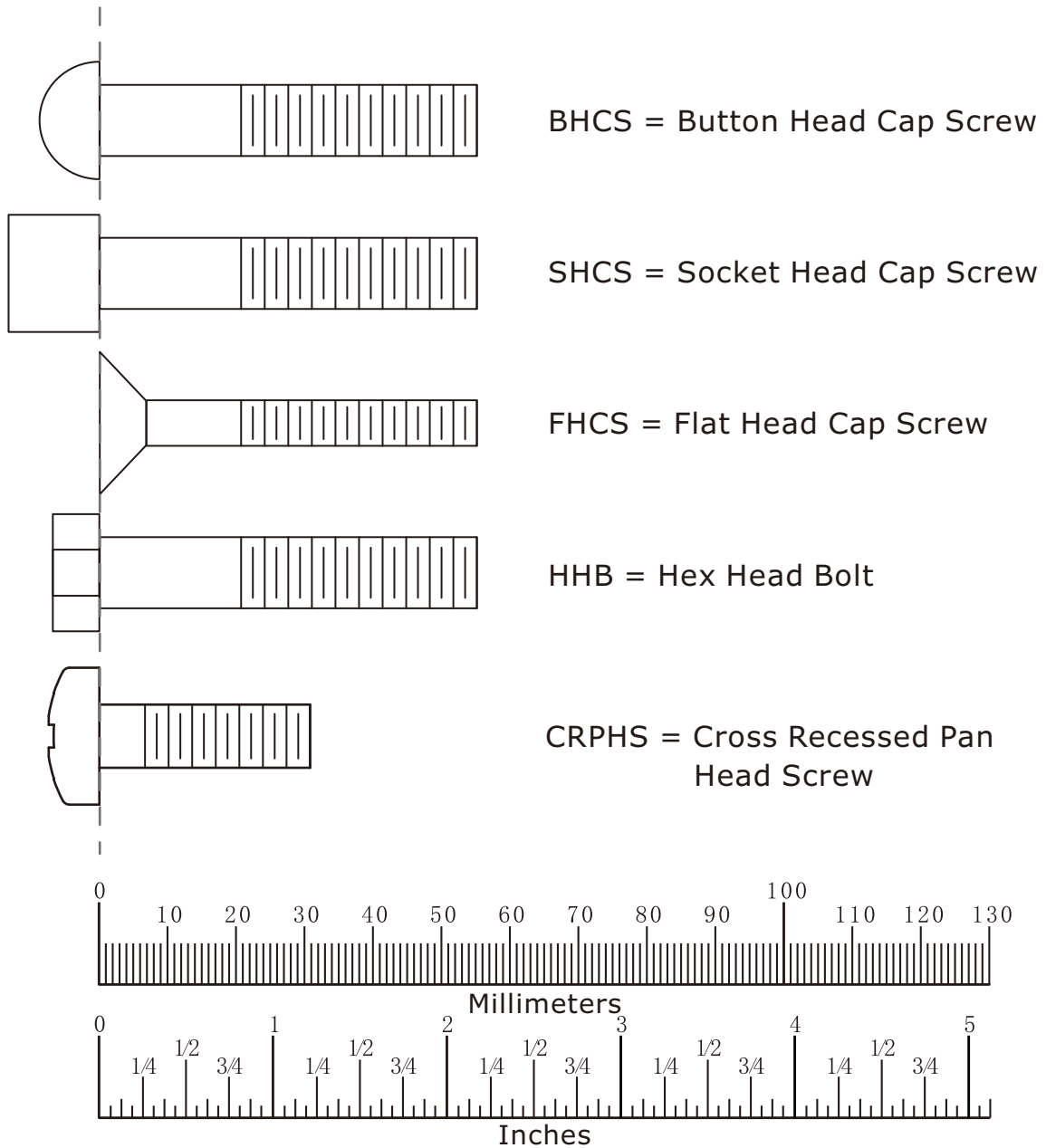

Diameter of bolt (mm/inch)	M6(1/4")	M8(5/16")	M10(3/8")	M12(1/2")	M16(5/8")
Tightening torque (N.m)	9~12	22~30	45~59	78~104	193~257
Operational methods for adult men	The strength of the wrist	The strength of the wrist and forearm	The strength of the entire arm	The strength of the arm and upper body	with all strength

# Assembly Instructions

Assembly of the equipment takes professional installers about 2 hours. If this is the first time you have assembled this type of equipment, plan to spend more time. It is strongly recommended to assemble the equipment by professional installers. You may find it quicker, safer, easier to assemble this equipment with the help of a friend, as some of components may be large, heavy or awkward to handle alone. It is important that you assemble your product in a clean, clear, uncluttered area. This will enable you to move around the product while you are fitting components and reduce the possibility of injury during assembly.

## **NOTE**

As with any assembled part, proper alignment and adjustment is critical. While tightening the fasteners, be sure to leave room for adjustments. Do not fully tighten the fasteners until instructed to do so. Be careful to assemble the components in the sequence presented in this guide.







# Assembly

## STEP 3

**TIPS:** Firstly, attach one end of the Cable ASSY (#17) to the Arm Frame ASSY (#11). Before attach the 4.5" Pulley to the frame, you should lead the other end of the Cable ASSY (#17) across it.

1. Attach three 4.5" Pulley (Spacer) (#18) and one Cable Keeper (#20) to the Weight Stack Frame ASSY (#1) using:
  - three M10\*50 HHB (#36)
  - six  $\Phi 11 \times \Phi 20 \times 2$  Flat Washer (#30)
  - three M10 Nylon Lock Nut (#33)
2. Attach the Front Bracket ASSY (#4) to the Weight Stack Frame ASSY (#1) using:
  - four Cross Disc Self Tapping Screw ST4.2\*16 (#32)

**Note: Wrench Tighten Bolts and Nylon Lock Nuts.**

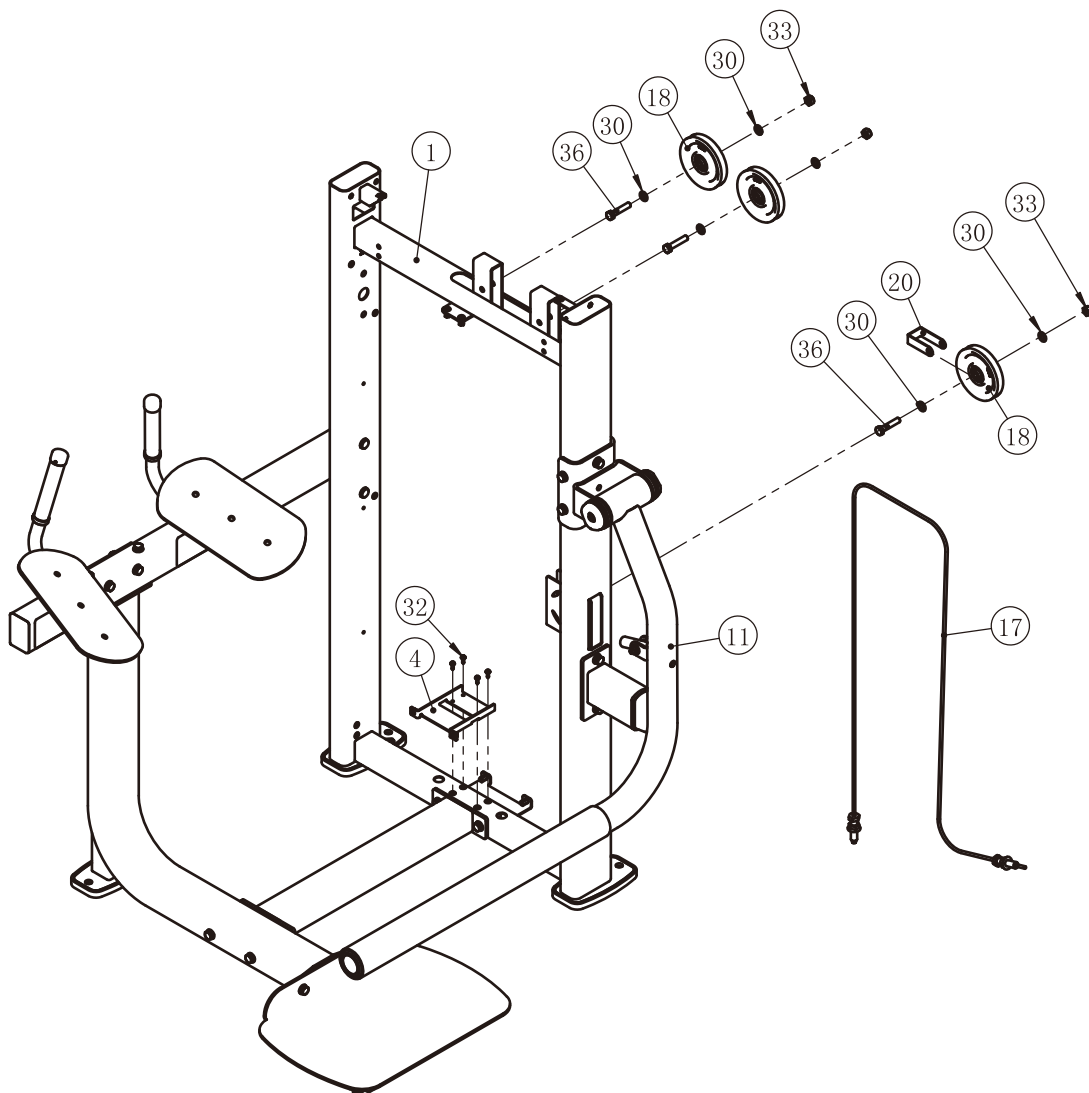

# Assembly

## STEP 4

Here is the assembly instruction for **160LBS Weights !**

### 1. Attach:

two Guide Rod  $\Phi 19 \times 1242$  (#3)

two Weight Rubber Bumper (#27)

fifteen Weight Plate 10LBS (#101)

two weight stack space (#103)

one Top Plate (#2)

to the Weight Stack Frame ASSY (#1) using:

two Guide Rod Fixing Sleeve  $\Phi 25 \times \Phi 19 \times 45$  (#28)

two Spring (#29)

### 2. Attach the Selector Pin W/Coil (#24) to the Top Plate (#2).

### 3. Attach the Cable ASSY (#17) to the Top Plate (#2).

Grade No.	Part No.	Description	QTY
101	FE97193100	10LBS Weight Plate	15
103	FEWS01ASSY	Weight Stack Space	2

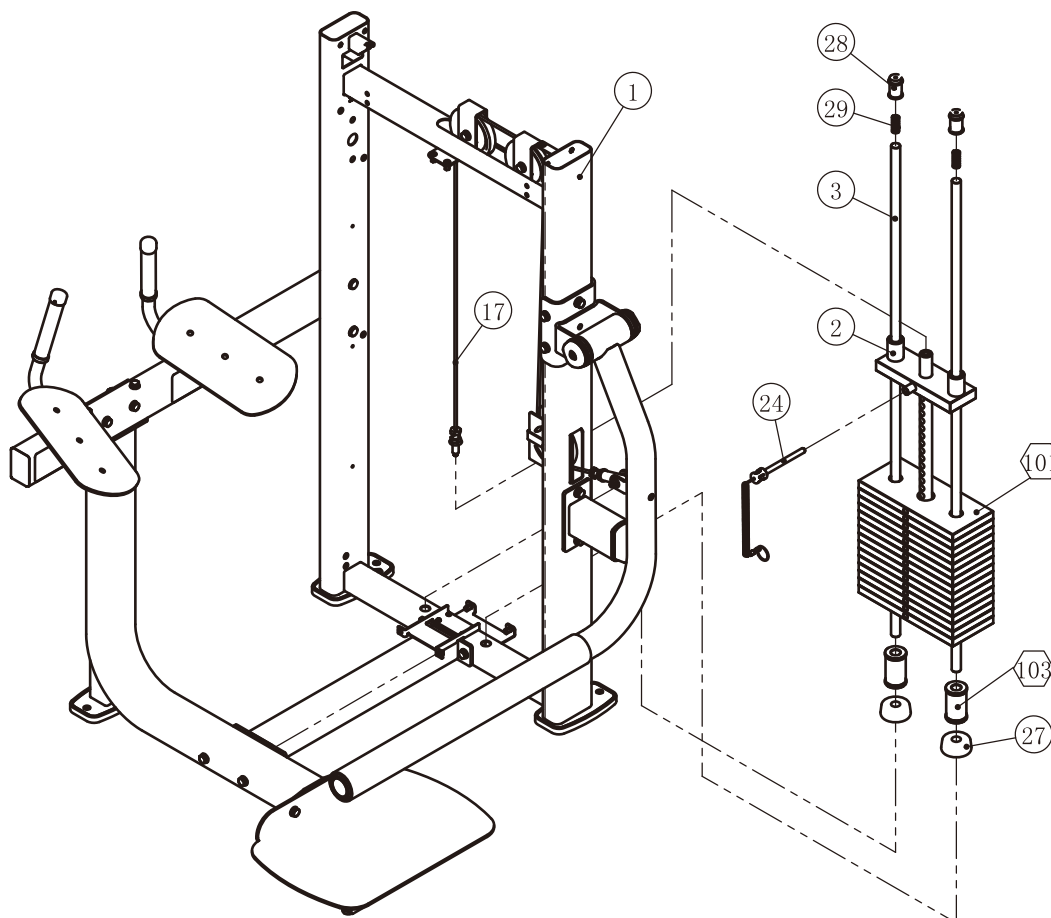

# Assembly

## STEP 4

Here is the assembly instruction for **200LBS Weights !**

### 1. Attach:

two Guide Rod  $\Phi 19 \times 1242$  (#3)

two Weight Rubber Bumper (#27)

nineteen Weight Plate 10LBS (#101)

one Top Plate (#2)

to the Weight Stack Frame ASSY (#1) using:

two Guide Rod Fixing Sleeve  $\Phi 25 \times \Phi 19 \times 45$  (#28)

two Spring (#29)

### 2. Attach the Selector Pin W/Coil (#24) to the Top Plate (#2).

### 3. Attach the Cable ASSY (#17) to the Top Plate (#2).

Grade No.	Part No.	Description	QTY
101	FE97193100	10LBS Weight Plate	19

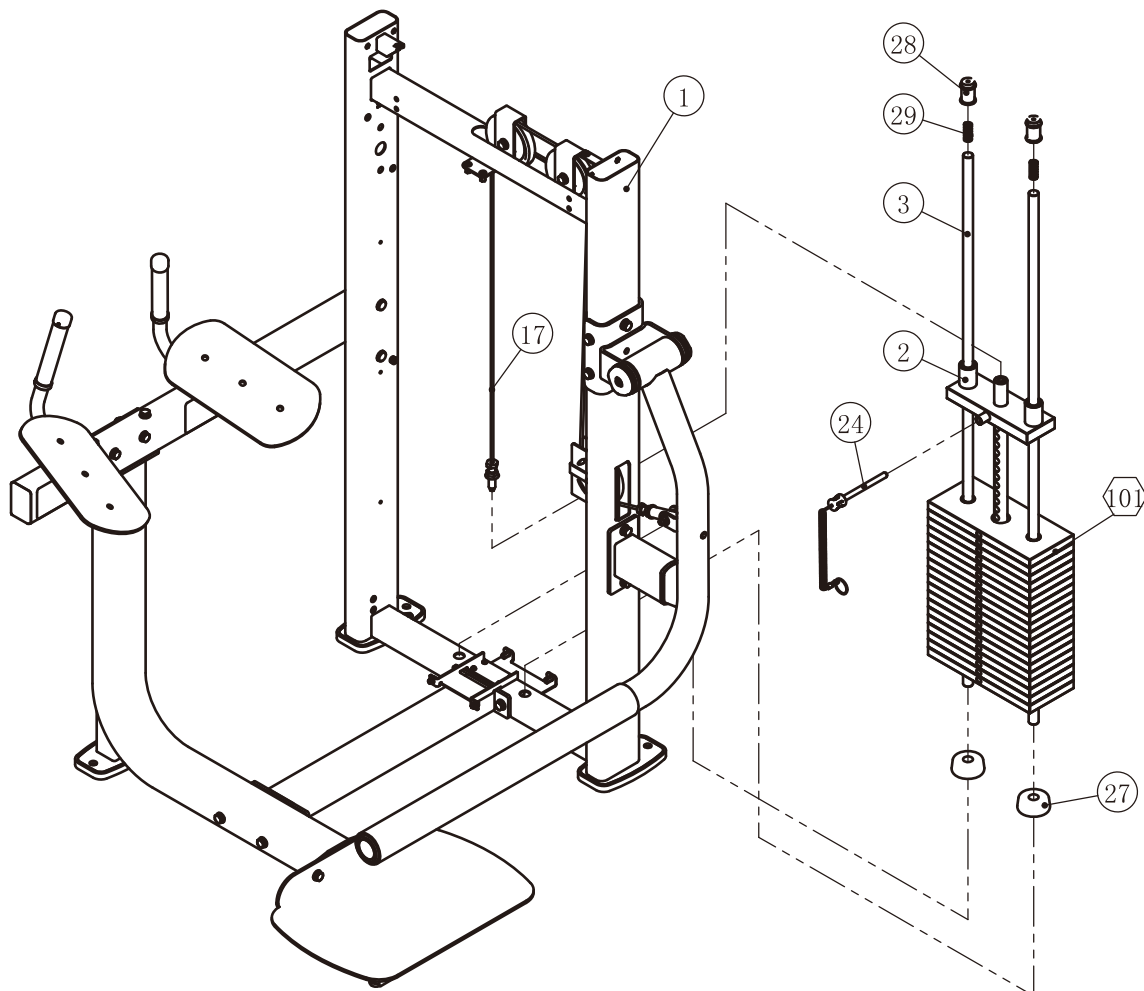

# Assembly

## STEP 4

Here is the assembly instruction for **235LBS Weights !**

### 1. Attach:

two Guide Rod  $\Phi 19 \times 1242$  (#3)

two Weight Rubber Bumper (#27)

fifteen Weight Plate 15LBS (#102)

two weight stack space (#103)

one Top Plate (#2)

to the Weight Stack Frame ASSY (#1) using:

two Guide Rod Fixing Sleeve  $\Phi 25 \times \Phi 19 \times 45$  (#28)

two Spring (#29)

### 2. Attach the Selector Pin W/Coil (#24) to the Top Plate (#2).

### 3. Attach the Cable ASSY (#17) to the Top Plate (#2).

Grade No.	Part No.	Description	QTY
102	FE97193200	15LBS Weight Plate	15
103	FEWS01ASSY	Weight Stack Space	2

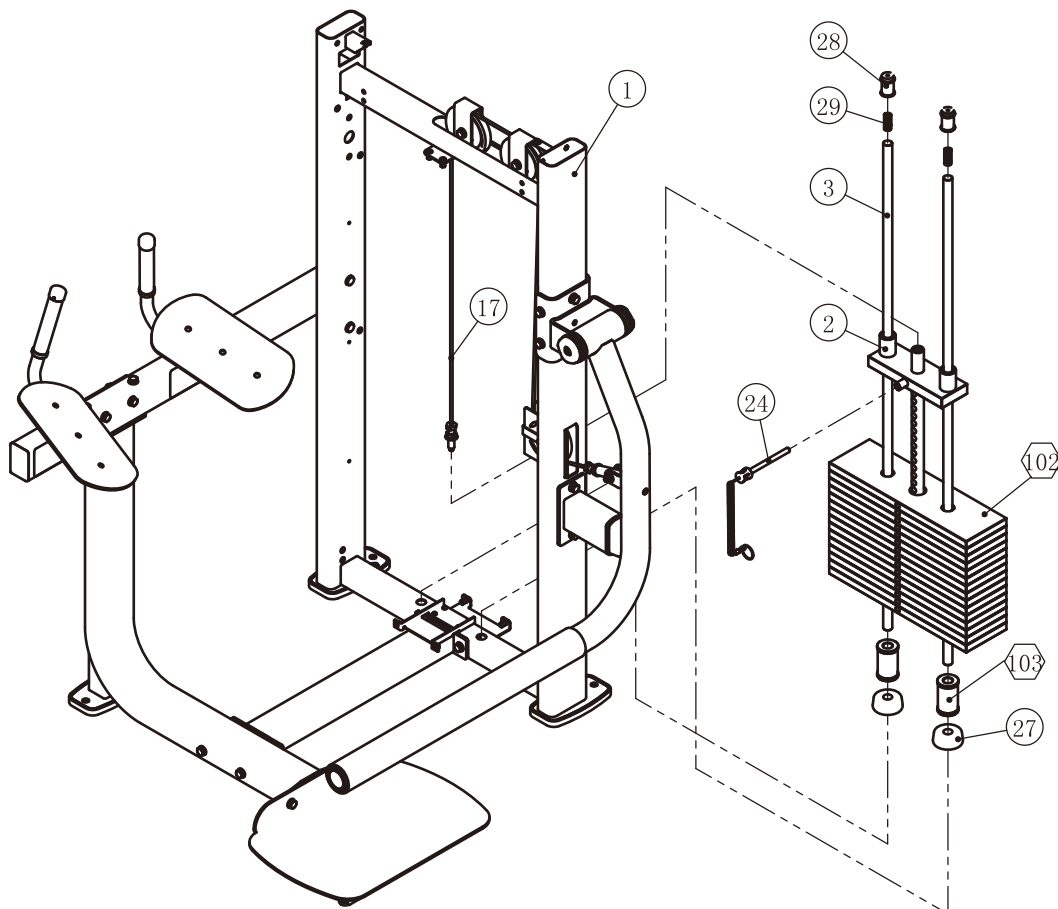

# Assembly

## STEP 4

Here is the assembly instruction for **295LBS Weights !**

### 1. Attach:

two Guide Rod  $\Phi 19 \times 1242$  (#3)

two Weight Rubber Bumper (#27)

nineteen Weight Plate 15LBS (#102)

one Top Plate (#2)

to the Weight Stack Frame ASSY (#1) using:

two Guide Rod Fixing Sleeve  $\Phi 25 \times \Phi 19 \times 45$  (#28)

two Spring (#29)

### 2. Attach the Selector Pin W/Coil (#24) to the Top Plate (#2).

### 3. Attach the Cable ASSY (#17) to the Top Plate (#2).

Grade No.	Part No.	Description	QTY
102	FE97193200	15LBS Weight Plate	19

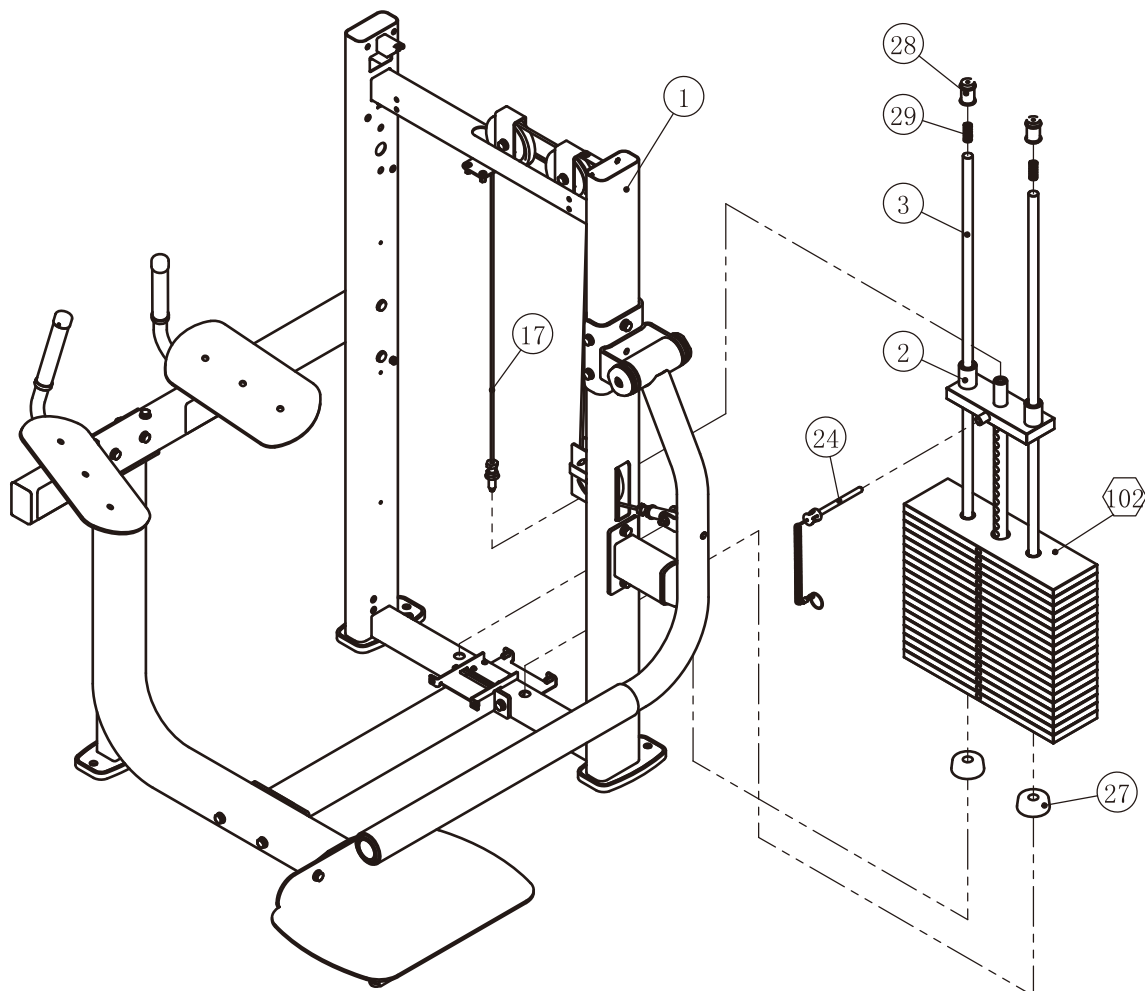

# Assembly

## All weight plate sticker paste schematic diagram

LBS 20	9
LBS 30	14
LBS 40	18
LBS 50	23
LBS 60	27
LBS 70	32
LBS 80	36
LBS 90	41
LBS 100	45
LBS 110	50
LBS 120	54
LBS 130	59
LBS 140	64
LBS 150	68
LBS 160	73
LBS 170	77
LBS 180	82
LBS 190	86
LBS 200	91
LBS 210	95
LBS 220	100
LBS 230	104

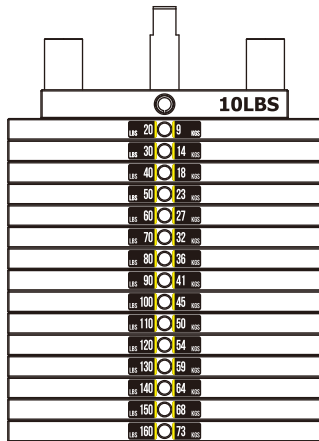

20-160LBS

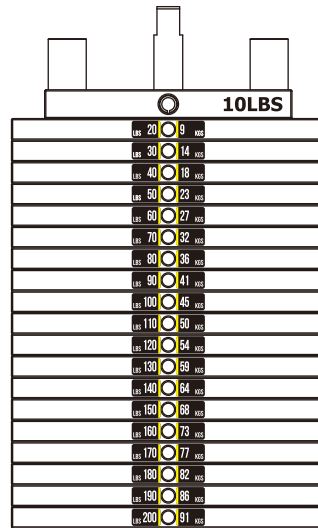

20-200LBS

LBS 25	11
LBS 40	18
LBS 55	25
LBS 70	32
LBS 85	38
LBS 100	45
LBS 115	52
LBS 130	59
LBS 145	66
LBS 160	72
LBS 175	79
LBS 190	86
LBS 205	93
LBS 220	100
LBS 235	107
LBS 250	113
LBS 265	120
LBS 280	127
LBS 295	134
LBS 310	141
LBS 325	147

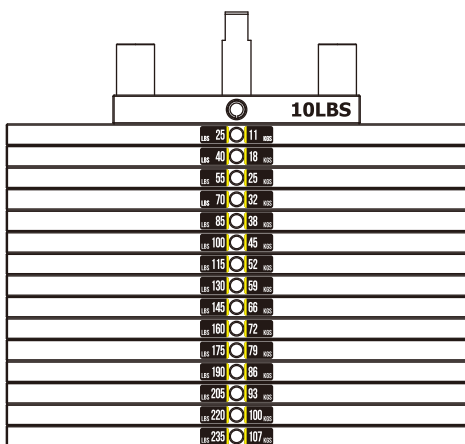

25-235LBS

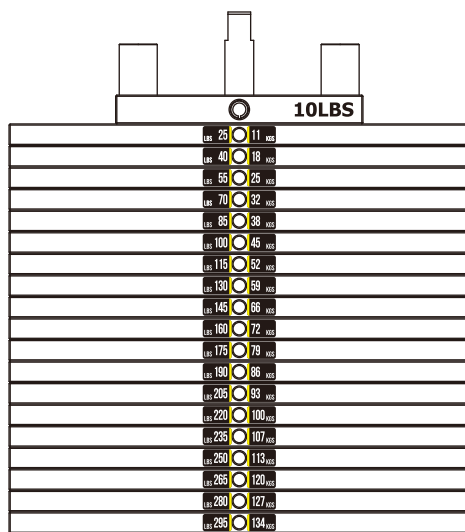

25-295LBS

# Assembly

## STEP 5

1. Attach the Rear Shroud (#22) to the Weight Stack Frame ASSY (#1) and the Bottom Bracket ASSY (#9) using:  
eight M6\*20 CRPHS (#31)
2. Attach the Left Bracket ASSY (#7) and the Right Bracket ASSY (#8) to the Weight Stack Frame ASSY (#1) using:  
four Cross Disc Self Tapping Screw ST4.2\*16 (#32)
3. Attach the Front Shroud (#21) to the Weight Stack Frame ASSY (#1), the Front Bracket ASSY (#4), the Left Bracket ASSY (#7) and the Right Bracket ASSY (#8) using:  
four Cross Disc Self Tapping Screw ST4.2\*16 (#32)  
two M6\*20 CRPHS (#31)
4. Attach the Top Cover (#5) to the Weight Stack Frame ASSY (#1) using:  
two M6\*20 CRPHS (#31)
5. Attach the Spout Plug (#6) to the Weight Stack Frame ASSY (#1).

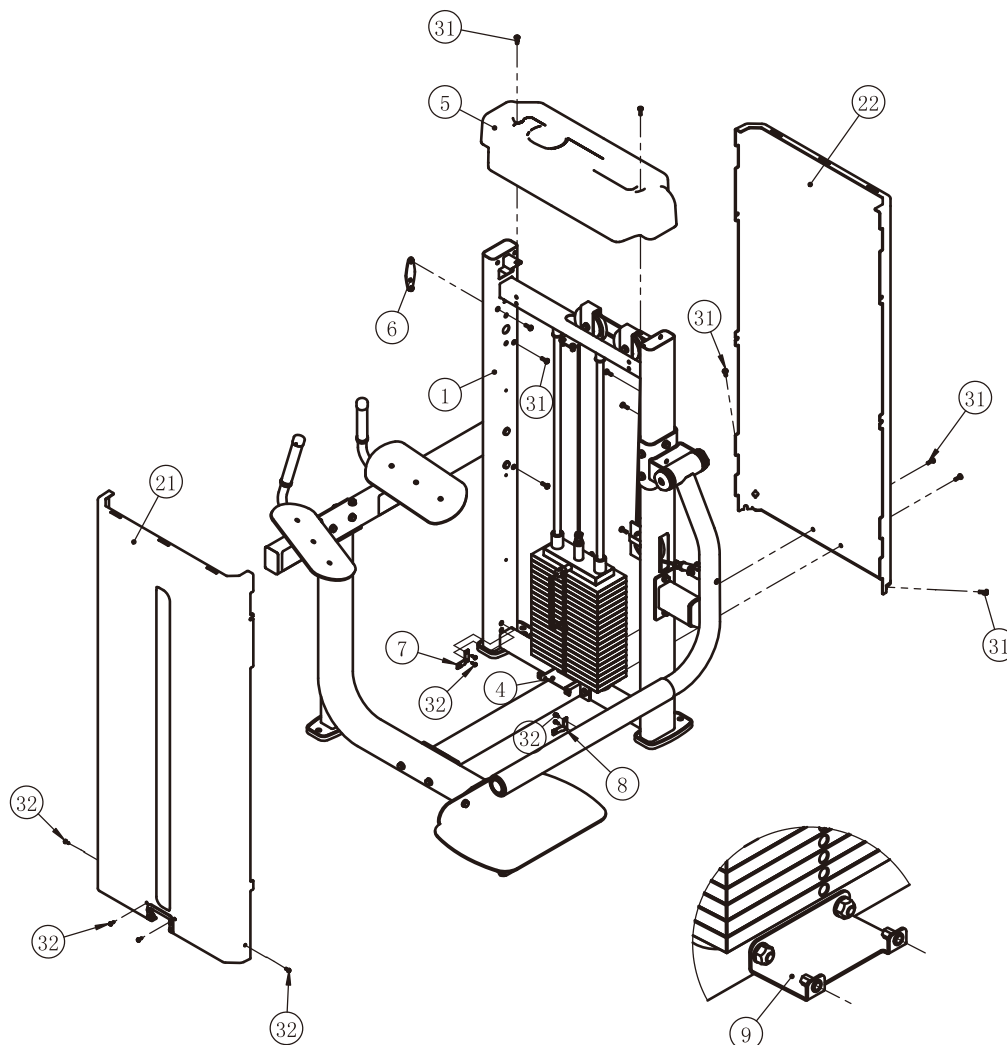



# Assembly

## STEP 6

Attach two Arm Pad (#23) to the Arm Frame ASSY (#12) using:

four M10\*30 HHB (#39)

four  $\Phi 11*\Phi 20*2$  Flat Washer (#30)

**Note: Wrench tighten bolts and nylon lock nuts.**

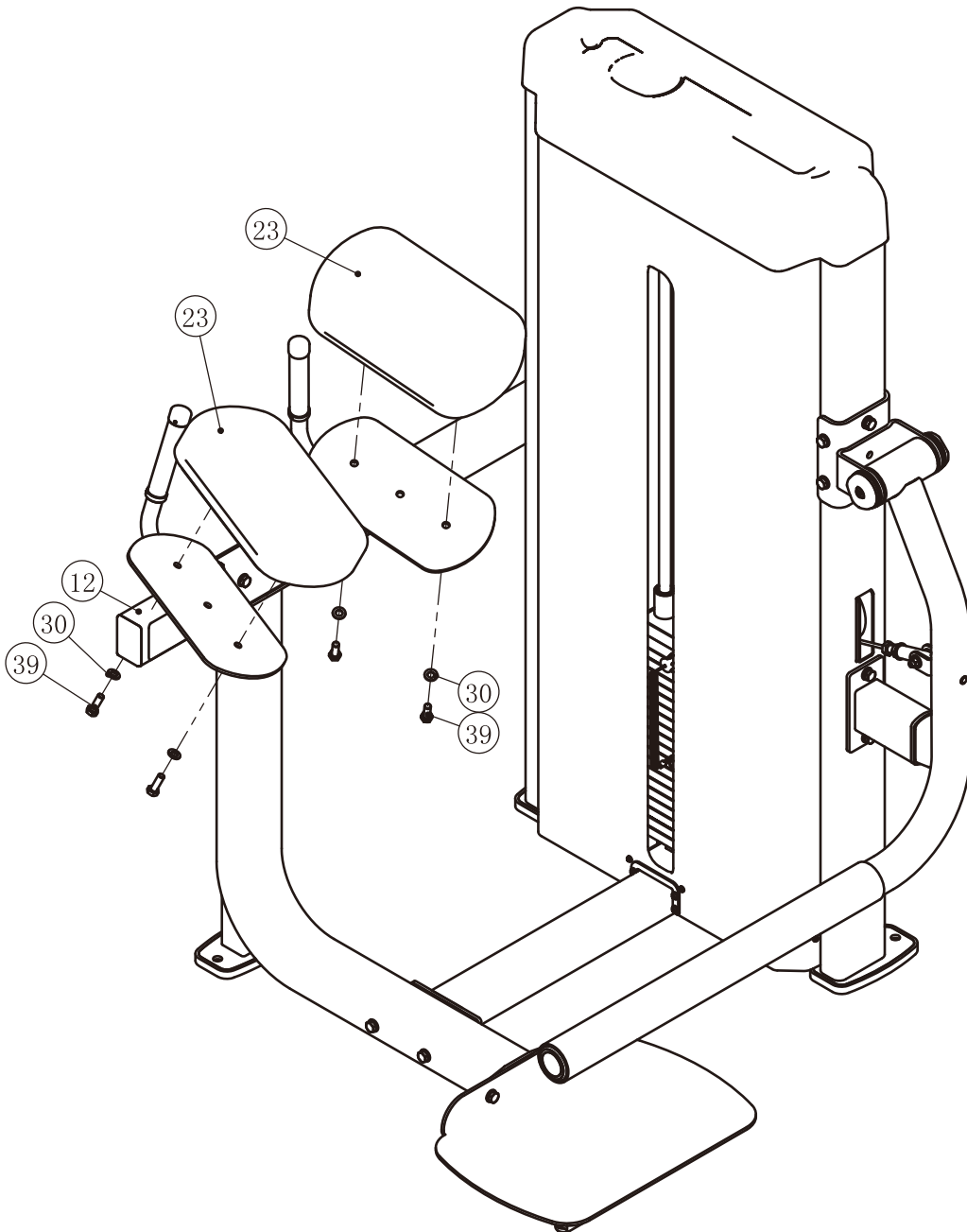

# Adjust Instructions and Exercise Instructions

## The use of Selector Pin W/Coil

1. Select an appropriate weight and put the Selector Pin W/Coil into the hole on it.
2. Make sure the Selector Pin W/Coil gets into the hole completely.

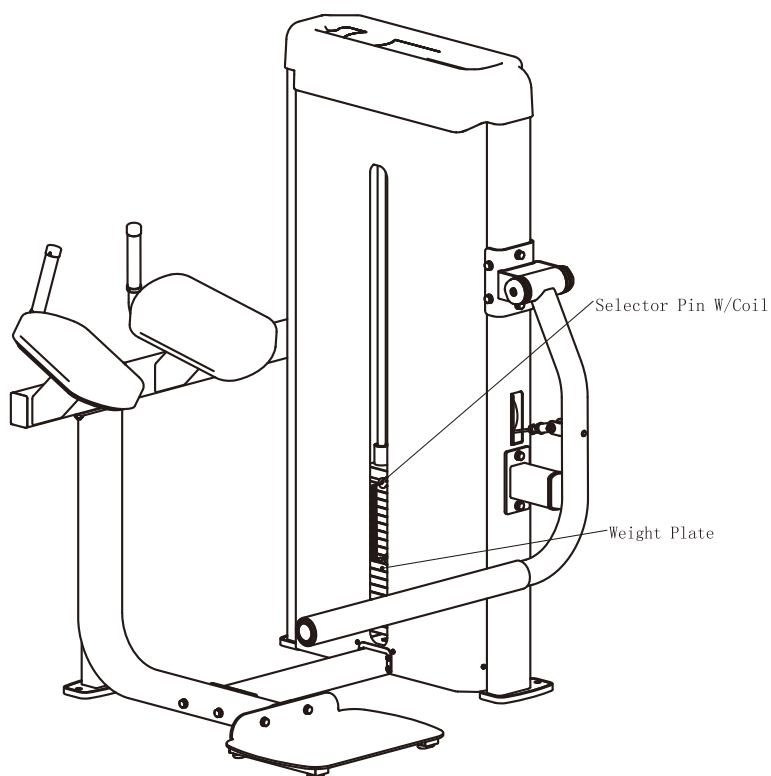

**FORZABOLD**  
**GLUTE**  
**FB51**

Start

Finish

**BODYTONE**

The complex block contains text, an anatomical diagram, and two photographs. On the left, the text 'FORZABOLD', 'GLUTE', and 'FB51' is displayed. Below the text is a line drawing of a human figure from the waist down, with the glute muscles highlighted in green. To the right of the anatomical diagram are two photographs of a person using the machine. The first photograph is labeled 'Start' and shows the person in a starting position. The second photograph is labeled 'Finish' and shows the person in a finishing position. The brand name 'BODYTONE' is printed at the bottom of the block.

# Maintenance Schedule

ROUTINE	COMMERCIAL MAINTENANCE	HOME MAINTENANCE	LATEST DATE ENTRY					
Inspect; Links, Pull Pins, Snap Locks, Swivels, Weight Stack Pins	DAILY	WEEKLY						
Clean; Upholstery	DAILY	WEEKLY						
Inspect; Cables or Belts and their tension	DAILY	WEEKLY						
Inspect; Accessory Bars, and Handles	WEEKLY	3 MONTHS						
Inspect; All Decals	WEEKLY	3 MONTHS						
Inspect; All Nuts and Bolts, Tighten if needed	WEEKLY	3 MONTHS						
Inspect; Anti-Skid Surface	WEEKLY	3 MONTHS						
Clean & Lubricate; Guide Rods with a Teflon (PTFE) based lubricant (Superlube)	MONTHLY	3 MONTHS						
Lubricate; Seat Sleeves, Turcite Bushings, Linear Bearing	MONTHLY	3 MONTHS						
Clean and Wax; All Glossy Finishes	6 MONTHS	YEARLY						
Repack with Grease; Linear Bearings	6 MONTHS	YEARLY						
Replace; Cables, Belts and Connecting Parts	YEARLY	3 YEARS						

*Your equipment comes with a commercial maintenance decal. For personal, in home use, please follow the home maintenance schedule listed above.*

# General Maintenance Information

## **Links, Pull-Pins, Snap Hooks, Swivels, Weight Stack Pins:**

- \* Check all pieces for signs of visible wear or damage.
- \* Check springs in snap hooks and pull-pins for proper tension and alignment.
- \* If the spring sticks or has lost its rigidity, replace it immediately.

## **Upholstery:**

- \* To ensure prolonged upholstery life and proper hygiene, all upholstered pads should be wiped down with a damp cloth after every workout.
- \* Periodically take the time to use a mild soap or an approved vinyl upholstery cleaner to deter the onset of cracking or drying. Avoid using any abrasive cleaners or cleaners not intended for use on vinyl.
- \* Replace ripped or worn upholstery immediately.
- \* Keep sharp or pointed objects clear of all upholstery.

## **Decals:**

- \* Inspect and familiarize yourself with any safety warnings or other user information posted on each decal.

## **Nuts and Bolts:**

- \* Inspect all nuts and bolts for any loosening and tighten if needed.
- \* Go through a re-tightening sequence periodically to ensure that all hardware is tensioned proper.

## **Anti-Skid Surfaces:**

- \* These surfaces are designed to supply secure footing and need to be replaced if they appear worn or become slippery.

## **Belts and Cables:**

- \* We use only high quality belt, and mil-spec cables.
- \* Visually inspect the belts and cables for fraying, cracking, peeling or discoloration.
- \* While the machine is not in use, carefully run your fingers along the belt or cable to feel for thinning or bulging areas.
- \* Replace belts and cables immediately at the first signs of damage or wear. Do not use equipment until belts or cables have been replaced.

## **Belt and Cable Tension:**

- \* Referring to the Owners Manual, when belts or cables are used check all bolt attachments to be sure they are properly attached.
- \* Check slack in cables and re-adjust cable tension if needed.

## **Seat Sleeves, Guide Rods:**

- \* Wipe down adjusting tubes with a dust free rag before applying lubricant.
- \* Lubricate seat sleeves and Guide Rods with a Silicon or Teflon based lubricant spray.

## **Linear Bearings:**

- \* Referring to the Owners Manual carefully disassemble the bearing from its housing and place a finger full of light grease (lithium, super lube, etc.) into the inside of the bearing. Using your finger, press the grease into the ball-bearings and their tracks. Repeat until the ball-bearing tracks are full of grease. Insert the shaft back into the bearing and wipe off excess grease.

**PLEASE KEEP THIS FOR YOUR RECORDS**

## Weight Training Tips

Use this manual to guide you through the basic exercises you can perform on your equipment. To gain maximum results and avoid possible injury, consult a fitness professional to develop your complete exercise program.

Always consult your physician before starting any exercise program.

To be successful in your exercise program, it is important to develop an understanding of the basic principles of strength training. Now that you have your equipment, it is only natural that you want to get started immediately. First, determine a set of realistic goals and objectives for yourself. By deciding on an exercise plan that is right for you prior to starting, you will contribute significantly to your success.

Warm up properly before engaging in weight resistance training. Stretching, yoga, jogging, calisthenics or other cardiovascular exercise can help prepare your body for the heavier workload of lifting weights.

Learn how to perform the exercise correctly before using heavy weight. Correct form is important to avoid injury and to ensure that you work the proper muscle groups.

Know your limitations. If you are new to weight training or are embarking on an exercise regimen after a long layoff, start slowly and build foundational strength over a longer period of time.

Pay attention to your breathing. Exhale when you exert is a general rule of thumb. Never hold your breath.



***BODYTONE***



[bodytone.eu](http://bodytone.eu)