

BODYTONE

FORZABOLD

FB31

TRICEPS



OWNER'S MANUAL

!CAUTION!

Read all precautions and instructions in this manual before using this equipment.

Table Of Contents

CAUTION!

Read all precautions and instructions in this manual before using this equipment.

Important Safety Instructions-----	3
Instructions-----	5
Exploded View and Parts List-----	6
Measurement Guide-----	14
Assembly Instructions-----	15
Assembly-----	16
Adjust Instructions and Exercise Instructions-----	26
Maintenance Schedule-----	27
General Maintenance Information-----	28
Weight Training Tips-----	29

Please assemble according to the actual **Weights** you buy !

Important Safety Instructions

Before beginning any fitness program, you should obtain a complete physical examination from your physician. When using exercise equipment, basic precautions should always be taken, including the following:

1. Read all instructions before using the equipment.
These instructions are written to ensure your safety and to protect the unit.
2. Use the equipment only for its intended purpose as described in this guide.
Do not use accessory attachments that are not recommended by the manufacturer: such attachments might cause injuries.
3. The product should only be used on a level surface and is with 0.6 meters space around the product.
Do not use the equipment outdoors.
4. Do not allow children on or near the equipment. And children are not allowed to use this equipment.
Teenagers should use this equipment with adult supervision.
5. Do not overexert yourself or work to exhaustion.
Do not attempt to lift more weight than you can control safely.
If you feel any pain or abnormal symptoms, stop your workout immediately and consult your physician.
6. This equipment is not used as medical apparatus and instruments.
7. Never operate the unit when it has been dropped or damaged.
Never drop or insert anything into any opening in the equipment.
Always check the unit and its cables before each use. Make sure that all fasteners and cables are secure and in good working condition.
Frayed or worn cables can be dangerous and may cause injury. Periodically check these cables for any indication of wear.
Keep hands, limbs, loose clothing and long hair well out of the way of moving parts.
8. Be careful when getting on or off the equipment.
9. Wear proper exercise clothing and shoes for your workout, no loose clothing.

Important Safety Instructions

Personal Safety During Assembly

Read each step in the assembly instructions and follow the steps in sequence. Do not skip ahead. If you skip ahead, you may learn later that you have to disassemble components and that you may have damaged the equipment.

Assemble and operate the equipment on a solid, level surface. Locate the unit a few feet from walls or furniture to provide easy access. The equipment is designed for your enjoyment. By following these precautions and using common sense, you will have many safe and pleasurable hours of healthful exercise with the equipment.

Training Area and Free Area

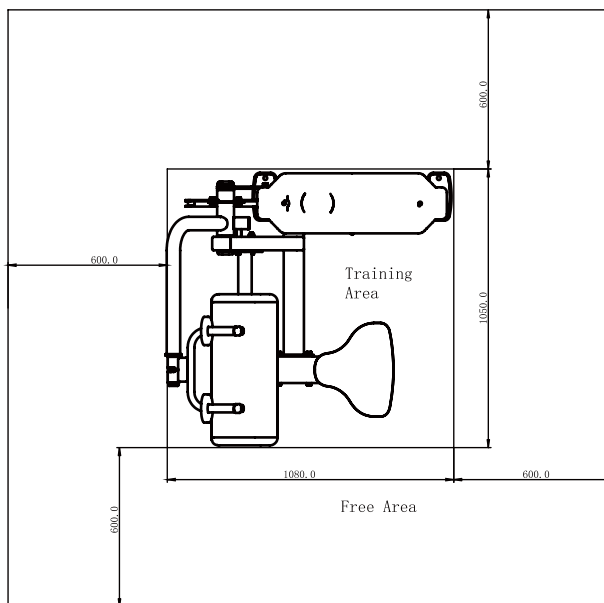

Specifications

Class: S

Maximum Wt. Capacity: 134kg/ 295lbs

Maximum User Weight: 150kg/ 330lbs

Product Dimension: 1078*1028*1504mm

Product Total Surface: 1080*1050mm

Product Total Mass:

Instructions

Before beginning assembly please take the time to read instructions thoroughly. Please use the various lists in this manual to make sure that all parts have been included in your shipment. When ordering, use part number and description from the lists. Use only our replacement part when servicing. Failure to do so will void your warranty and could result in personal injury.

The equipment is designed to provide the smoothest, most effective exercise motion possible. After assembly, you should check all functions to ensure correct operation. If you experience problems, first recheck the assembly instructions to locate any possible errors made during assembly. If you are unable to correct the problem, call your authorized dealer. Be sure to have your serial number and this manual when calling. When all parts have been accounted for, continue on.

Tools Required

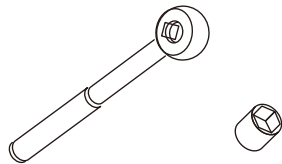

Ratchet Wrench and Socket

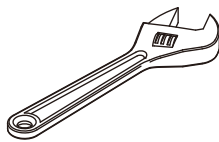

Adjustable Wrench



Rubber Mallet



Hex Key Wrench Set

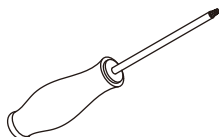

Phillips Screwdriver

Exploded View and Parts List

Overall

Item No.	Grade No.	Part No.	Description	QTY
1	1	FB3101ASSY	Weight Stack Frame ASSY	1
2	2	IT95014200	Top Plate	1
3	3	IT95081700	Guide Rod $\Phi 19 \times 1242$	2
4	4	IF9301B21ASSY	Front Bracket ASSY	1
5	5	FB013100	Top Cover	1
6	6	FB013400	Spout Plug	1
7	7	FB0135ASSY	Left Bracket ASSY	1
8	8	FB0136ASSY	Right Bracket ASSY	1
9	9	FB0137ASSY	Bottom Bracket ASSY	1
10	10	IF93230200	Seat Pad Support	1
11	11	IF932303ASSY	Bottom Cross Frame ASSY	1
12	12	IF932305ASSY	Swing Frame ASSY	1
13	13	IF932306ASSY	Arm Frame ASSY	1
14	14	IF93230700	Wheel Frame	1
15	15	IF930302ASSY	Main Frame ASSY	1
16	16	IF93030400	Upper Connection Frame	1
17	17	IF93050900	Main Bracket	1
18	18	IT80033100	Plate	1
19	19	IF93237500	Cable ASSY	1
20	20	SG500110400V5	4.5" Pulley (Spacer)	2
21	21	IT90012000V1	Selector Pin W/Coil	1
22	22	IT80023000	Weight Rubber Bumper	2
23	23	IT95016100	Guide Rod Fixing Sleeve $\Phi 25 \times \Phi 19 \times 45$	2
24	24	HFOPT900-04A0602	Spring $\Phi 15.5 \times \Phi 1.5 \times 36$	2
25	25	IT80124103	Split Pin $\Phi 11 \times 76$	1
26	26	FE97212000	Circle Ring $\Phi 62.5 \times 5$	2

Exploded View and Parts List

Overall

Item No.	Grade No.	Part No.	Description	QTY
27	27	FE97211900	Cap Φ 60	2
28	28	V22500	Plug	1
29	29	HFOPT900-04A1400	Aluminium Sheath	1
30	30	IN-D21202000	Aluminium Cap Φ 38* Φ 10.5*8	1
31	31	GB5780M10*120DS20	Hex Head Bolt M10*120	4
32	32	GB5780M10*75DS20	Hex Head Bolt M10*75	6
33	33	GB5780M10*50DS20	Hex Head Bolt M10*50	3
34	34	GB5780M10*30DS20	Hex Head Bolt M10*30	14
35	35	GB5781M10*25DS20	Hex Head Bolt M10*25	3
36	36	GB70M10*25DS20NL	Socket Head Cap Screw M10*25	1
37	37	GB70M10*15DS20	Socket Head Cap Screw M10*15	1
38	38	CNLM10*25DS20NL	Flat Head Cap Screw M10*25	1
39	39	GB818M6*20DHS2	Cross Recessed Pan Head Screw M6*20	12
40	40	GB9074ST4.2*16DHS	Cross Disc Self Tapping Screw ST4.2*16	12
41	41	NM10DS2	Nylon Lock Nut M10	16
42	42	GB9510DS2	Flat Washer Φ 11* Φ 20*2	45
43	43	GB9310DS12	Spring Washer Φ 10	3
44	44	FB303200	Front Shroud	1
45	45	FB013300	Rear Shroud	1
46	46	IT95033100V1	Arm Pad	1
47	47	IF93015200	Seat Pad	1
48		NBS6DHS	Hex Key S=6	1
49		NBS8DHS	Hex Key S=8	1
50		LW200BS	Wrench Φ 6*117	1
51		YHY	Lube	1

Exploded View and Parts List

Overall

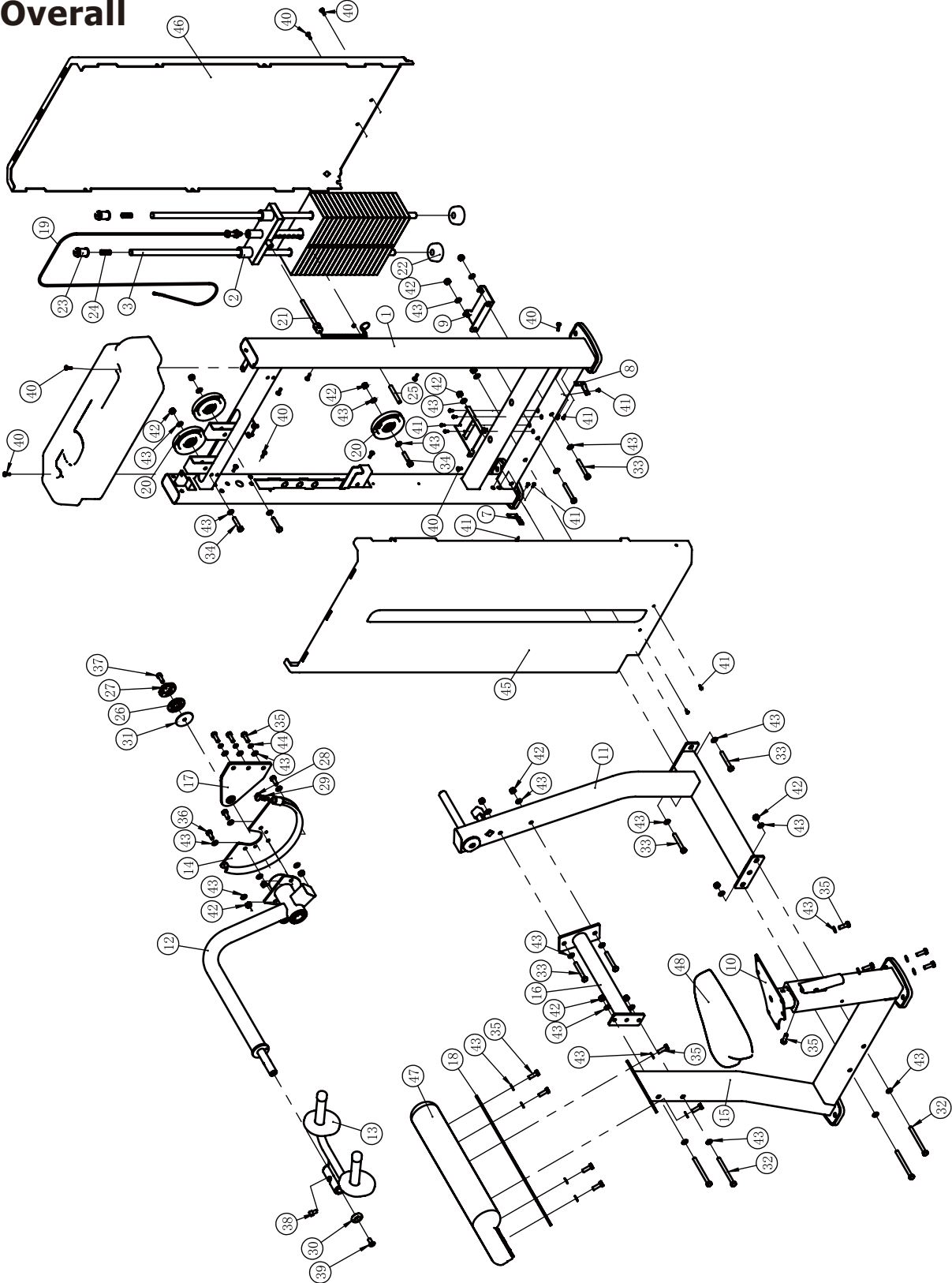

Exploded View and Parts List

Weight Stack Frame ASSY

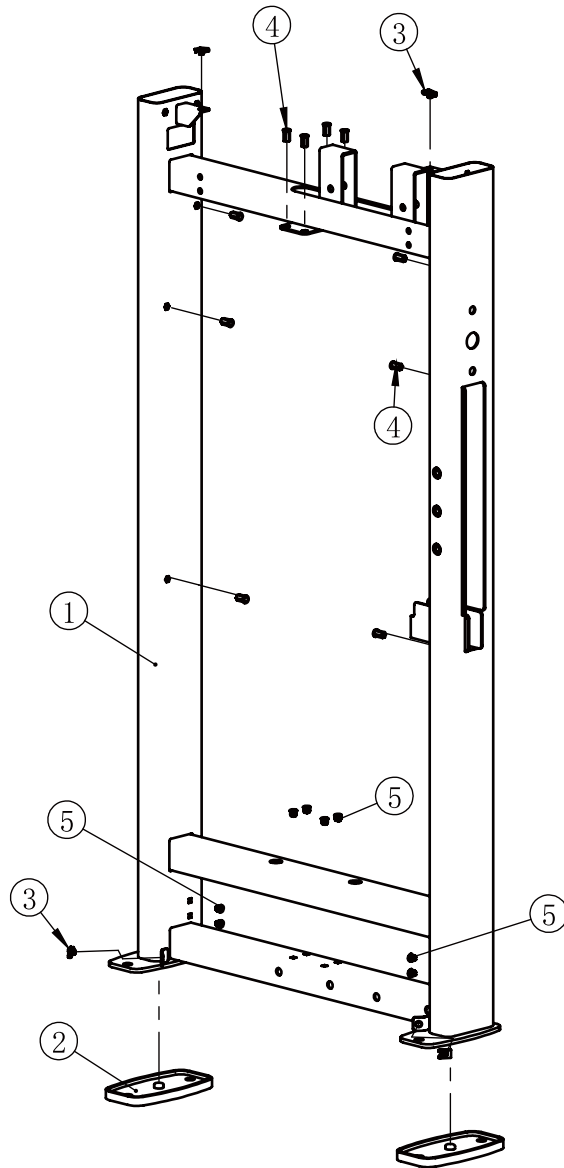

Item No.	Grade No.	Part No.	Description	QTY
1	1.1	IF9323ZN0100	Weight Stack Frame	1
2	1.2	BS81223100	Foot Plate	2
3	1.3	GB17880.5M6*16.5DS17	Rivet Nut M6	10
4	1.4	AC32705800	U-nut M6	4
5	1.5	ECU7P3500	Plastic Nut	8

Exploded View and Parts List

Left Bracket ASSY

7

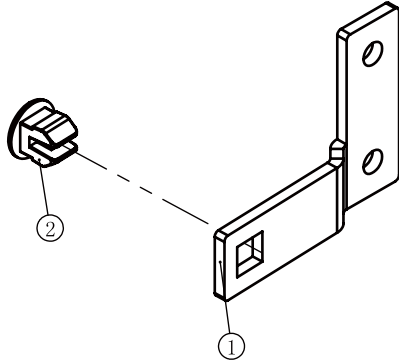

Right Bracket ASSY

8

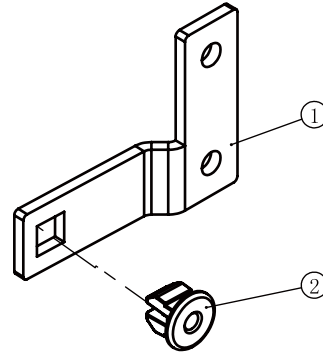

Bottom Bracket ASSY

9

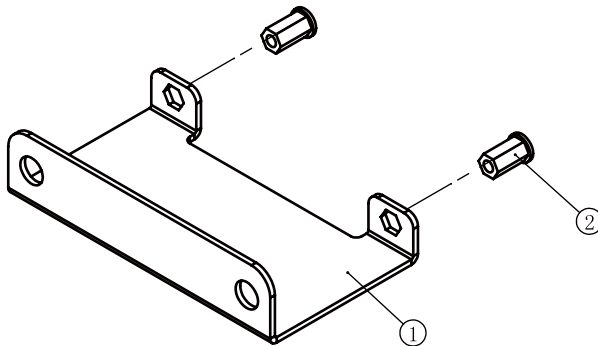

Front Bracket ASSY

4

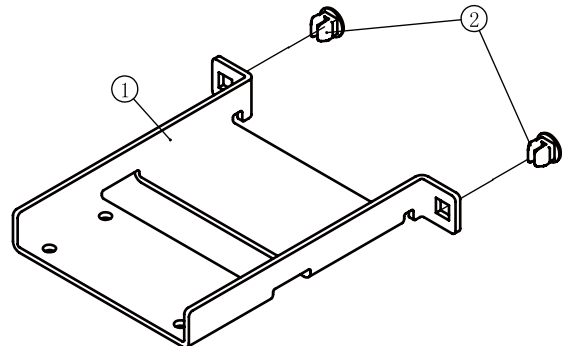

Item No.	Grade No.	Part No.	Description	QTY
1	7.1	FB013500	Left Bracket	1
2	7.2	ECU7P3500	Plastic Nut	1

Item No.	Grade No.	Part No.	Description	QTY
1	8.1	FB013600	Right Bracket	1
2	8.2	ECU7P3500	Plastic Nut	1

Item No.	Grade No.	Part No.	Description	QTY
1	9.1	FB013700	Bottom Bracket	1
2	9.2	GB17880.5M6*16.5DS17	Rivet Nut M6	2

Item No.	Grade No.	Part No.	Description	QTY
1	4.1	IF9301B21.00	Front Bracket	1
2	4.2	ECU7P3500	Plastic Nut	2

Exploded View and Parts List

Main Frame ASSY

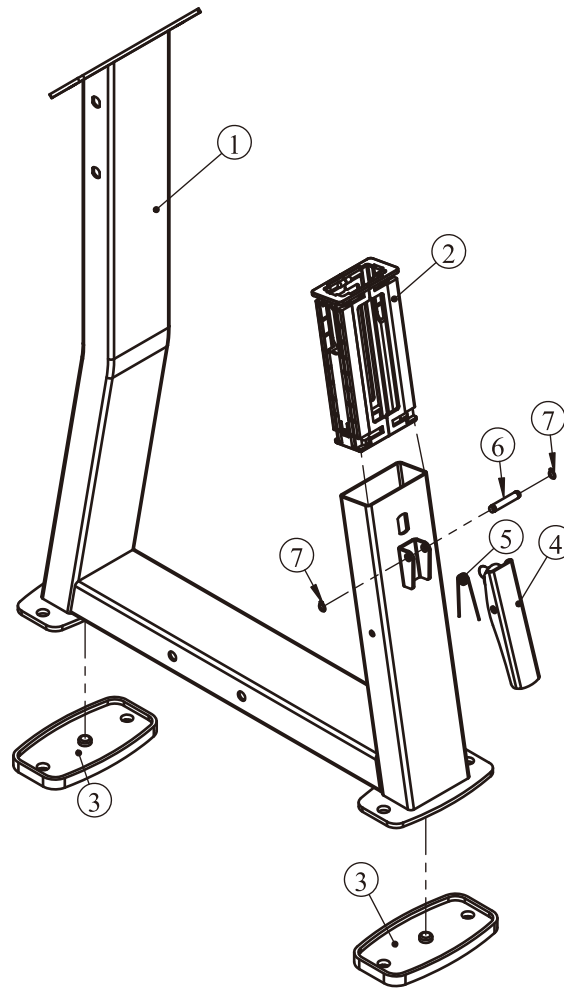

Item No.	Grade No.	Part No.	Description	QTY
1	11.1	IF93030200	Main Frame	1
2	11.2	IF93035000	Inner Wear Sleeve	2
3	11.3	BS81223100	Foot Plate	2
4	11.4	IT95014500	Adjustable Support	1
5	11.5	AXT3S5500	Torsional Spring	1
6	11.6	CWRVL0012200	Roll Pin	1
7	11.7	GB894.18FH12	Circlips For Shaft $\Phi 8$	2

Exploded View and Parts List

Bottom Cross Brace ASSY

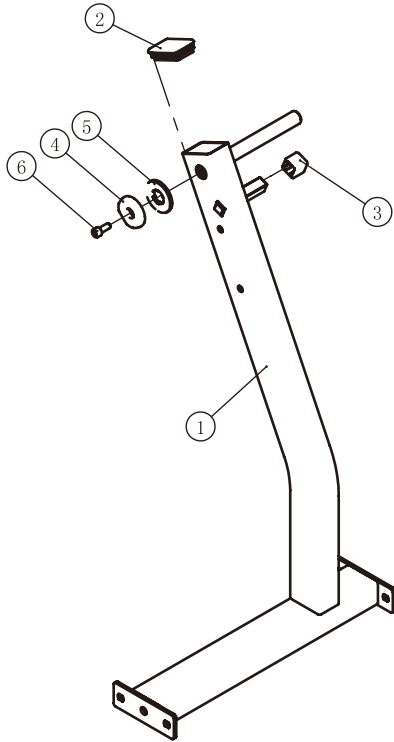

Swing Frame ASSY

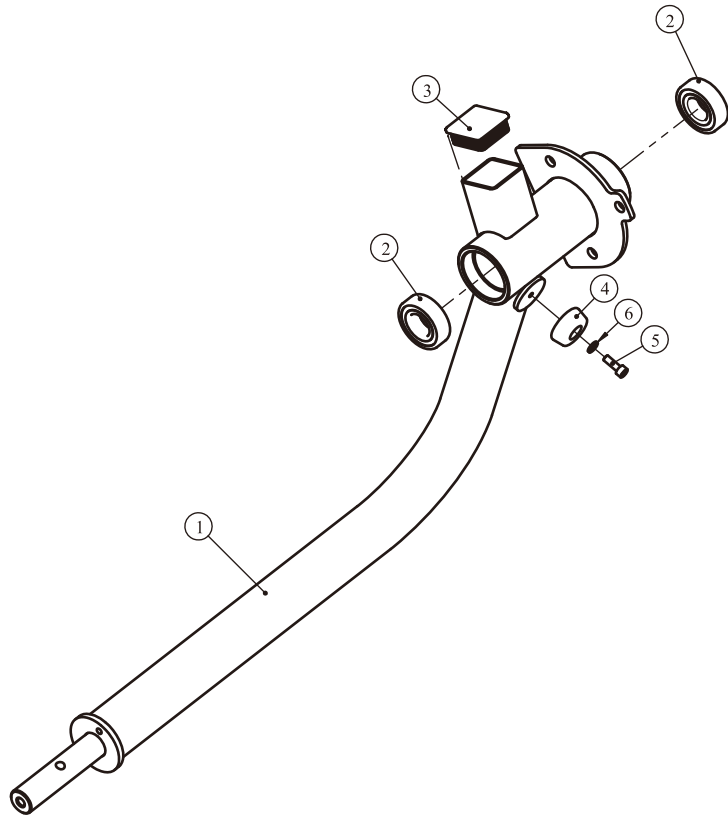

Item No.	Grade No.	Part No.	Description	QTY
1	12.1	IF93230300	Bottom Cross Brace	1
2	12.2	KPSFID2800	Plug □50.8*76.2	1
3	12.3	FE97213100	Square Rubber Sleeve	1
4	12.4	FE97211900	Cap Φ60	1
5	12.5	FE97212000	Circle Ring Φ62.5*5	1
6	12.6	GB70M10*25DS20	Socket Head Cap Screw M10*15	1

Item No.	Grade No.	Part No.	Description	QTY
1	13.1	IF93230500	Swing Frame	1
2	13.2	GB2766205-2ZC3	Deep Groove Ball Bearing Φ25*Φ52*15	2
3	13.3	BNH0053	Plug □44.5	1
4	13.4	PS10007100	Bummpner Φ38*Φ33*15	1
5	13.5	GB70M6*18DS20	Socket Head Cap Screw M6*18	1
6	13.6	GB956DS2	Washer Φ6.6*Φ12*1.6	1

Exploded View and Parts List

Arm Frame ASSY

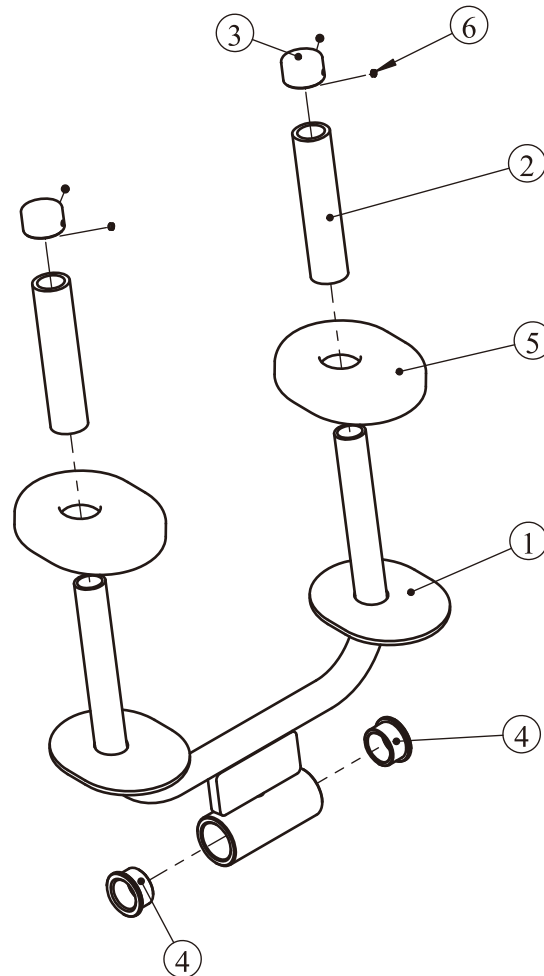

Item No.	Grade No.	Part No.	Description	QTY
1	14.1	IF93230600	Arm Frame	1
2	14.2	026-01PL0206-12	Grip STΦ31*Φ24*130	2
3	14.3	V39600	Aluminum Grip Cap	2
4	14.4	M02502000	Bushing Φ38*Φ25.4*18	2
5	14.5	TVS700262800	Rubber Bumper	2
6	14.6	YZGB7710-32*3.2N19	Socket Set Screw 10-32UNF*3.2	4

Measurement Guide

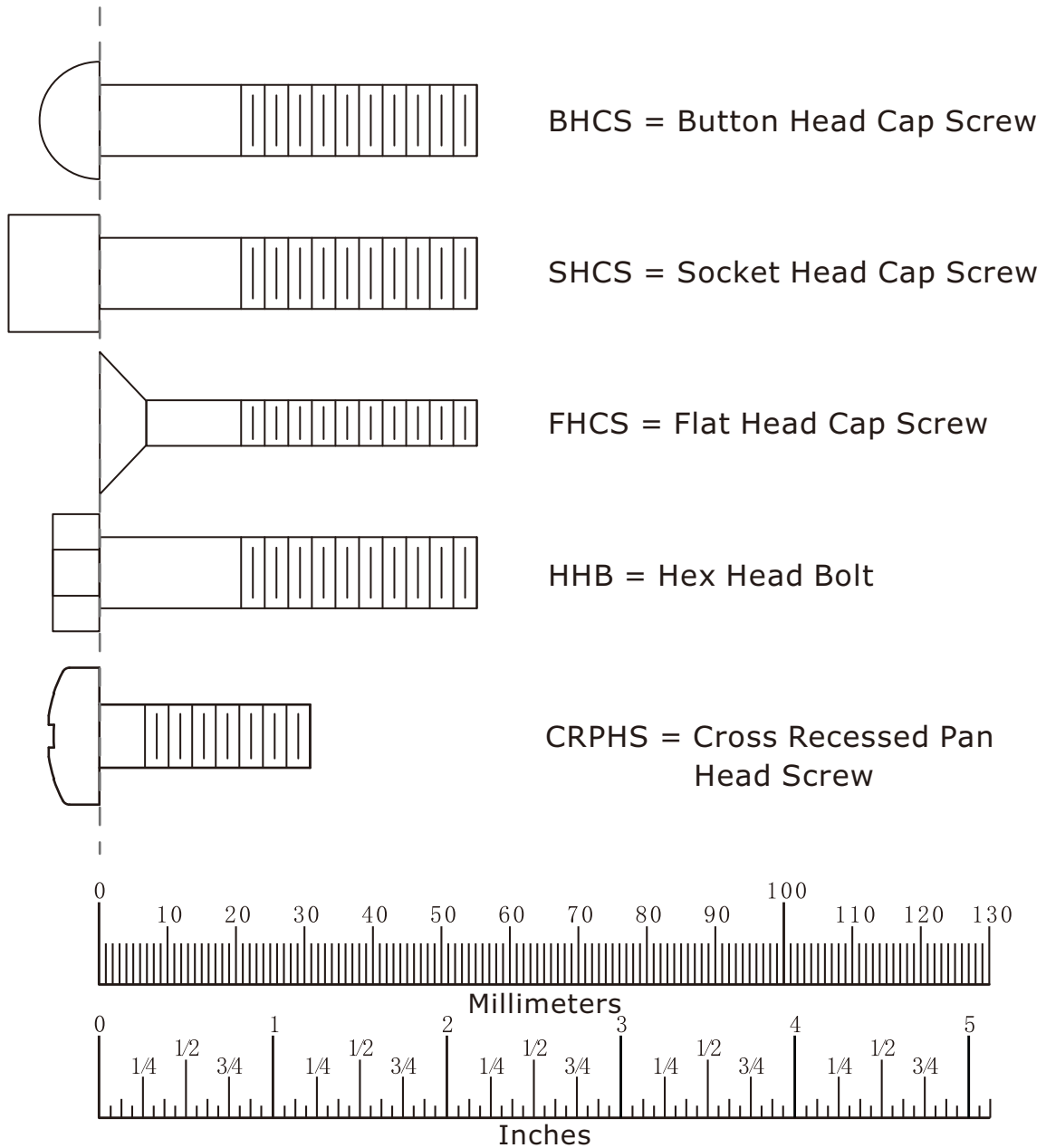

Diameter of bolt (mm/inch)	M6(1/4")	M8(5/16")	M10(3/8")	M12(1/2")	M16(5/8")
Tightening torque (N.m)	9~12	22~30	45~59	78~104	193~257
Operational methods for adult men	The strength of the wrist	The strength of the wrist and forearm	The strength of the entire arm	The strength of the arm and upper body	with all strength

Assembly Instructions

Assembly of the equipment takes professional installers about 2 hours. If this is the first time you have assembled this type of equipment, plan to spend more time. It is strongly recommended to assemble the equipment by professional installers. You may find it quicker, safer, easier to assemble this equipment with the help of a friend, as some of components may be large, heavy or awkward to handle alone. It is important that you assemble your product in a clean, clear, uncluttered area. This will enable you to move around the product while you are fitting components and reduce the possibility of injury during assembly.

NOTE

As with any assembled part, proper alignment and adjustment is critical. While tightening the fasteners, be sure to leave room for adjustments. Do not fully tighten the fasteners until instructed to do so. Be careful to assemble the components in the sequence presented in this guide.

Assembly

STEP 1

TIPS: Firstly, attach the Swing Frame ASSY (#12) to the Bottom Cross Brace ASSY (#11).

1. Attach the Bottom Cross Brace Frame ASSY (#11), Swing Frame ASSY (#12) and Main Bracket (#17) to the Weight Stack Frame ASSY (#1) using:

two $\Phi 60$ Cap (#27)

two $\Phi 62.5 \times 5$ Circle Ring (#26)

two M10*25 SHCS (#37)

two M10*75 HHB (#33)

three M10*30 HHB (#35)

two M10 Nylon Lock Nut (#42)

seven $\Phi 11 \times \Phi 20 \times 2$ Flat Washer (#43)

three $\Phi 10$ Spring Washer (#44)

2. Attach the Main Frame ASSY (#15) to the Bottom Cross Brace Frame (#11) using:

two M10*120 HHB (#32)

two M10 Nylon Lock Nut (#42)

four $\Phi 11 \times \Phi 20 \times 2$ Flat Washer (#43)

3. Attach the Upper Connection Frame (#16) to the Bottom Cross Brace Frame (#11) and the Main Frame ASSY (#15) using:

two M10*75 HHB (#33)

two M10*120 HHB (#32)

eight $\Phi 11 \times \Phi 20 \times 2$ Flat Washer (#43)

four M10 Nylon Lock Nut (#42)

Note: Wrench Tighten Bolts and Nylon Lock Nuts.

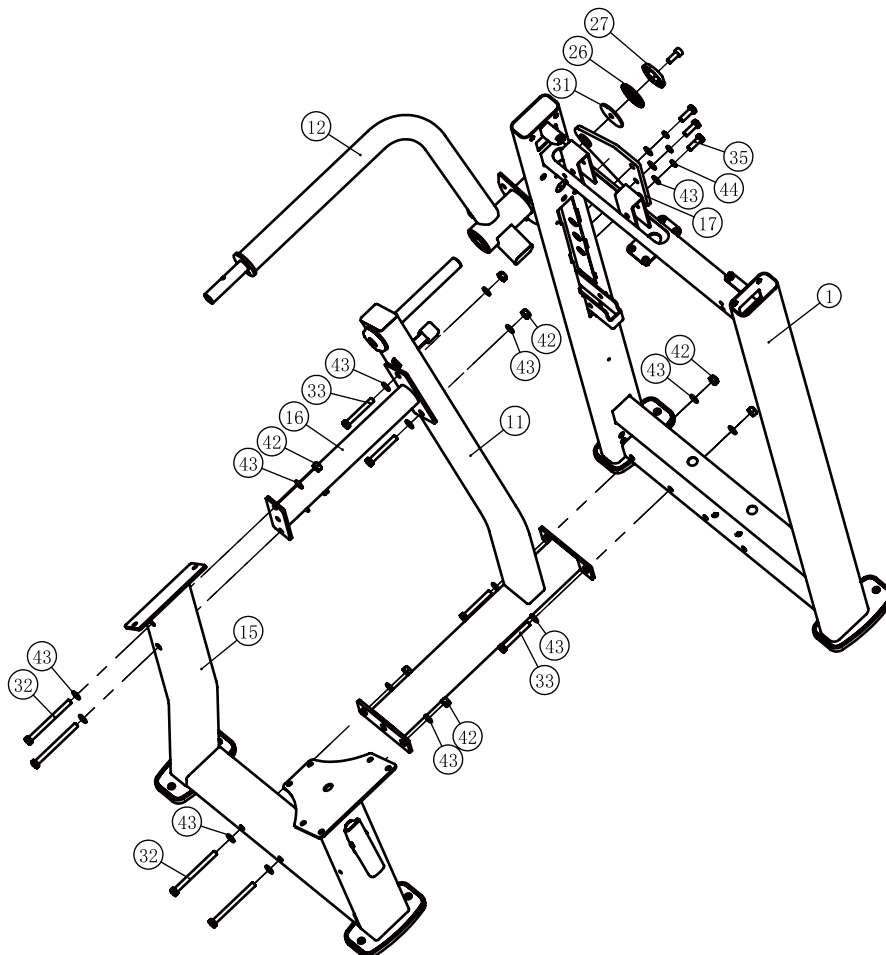

Assembly

STEP 2

1. Attach the Wheel Frame (#14) to the Swing Frame ASSY (#12) using:
three M10*25 HHB (#36) three M10 Nylon Lock Nut (#42)
six $\Phi 11*\Phi 20*2$ Flat Washer (#43)
2. Attach the Arm Frame ASSY (#13) to the Swing Frame ASSY (#12) using:
one Aluminium Cap $\Phi 38*\Phi 10.5*8$ (#30) one M10*15 SHCS (#38)
one M10*25 FHCS (#39)
3. Attach the Seat Pad Support (#10) and one M10*30 HHB (#35) to the Main Frame ASSY (#15).

Note: Wrench Tighten Bolts and Nylon Lock Nuts.

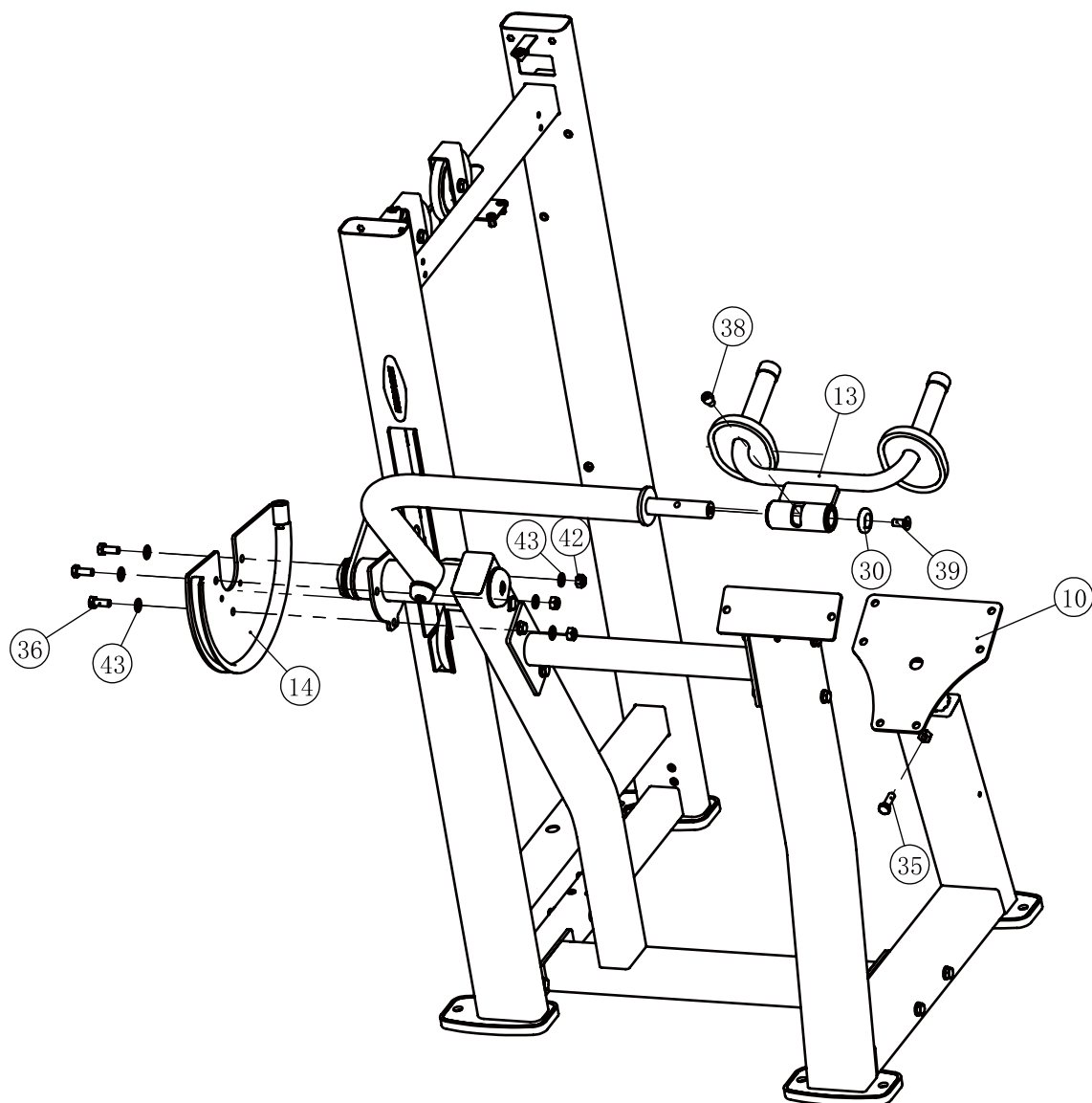

Assembly

STEP 3

1. Attach one end of the Cable ASSY (#19) to the Swing Frame ASSY (#13) using:
one Aluminium sheath (#29)

Before attach the 4.5" Pulley to the frame, you should lead the other end of the Cable ASSY (#19) across it.

2. Attach three 4.5" Pulley (Spacer) (#20) to the Weight Stack Frame ASSY (#1) using:
three M10*50 HHB (#34) three M10 Nylon Lock Nut (#42)
six Φ 11* Φ 20*2 Flat Washer (#43)

3. Attach the Plug (#28) to the Wheel Frame (#14).

Note: Wrench Tighten Bolts and Nylon Lock Nuts.

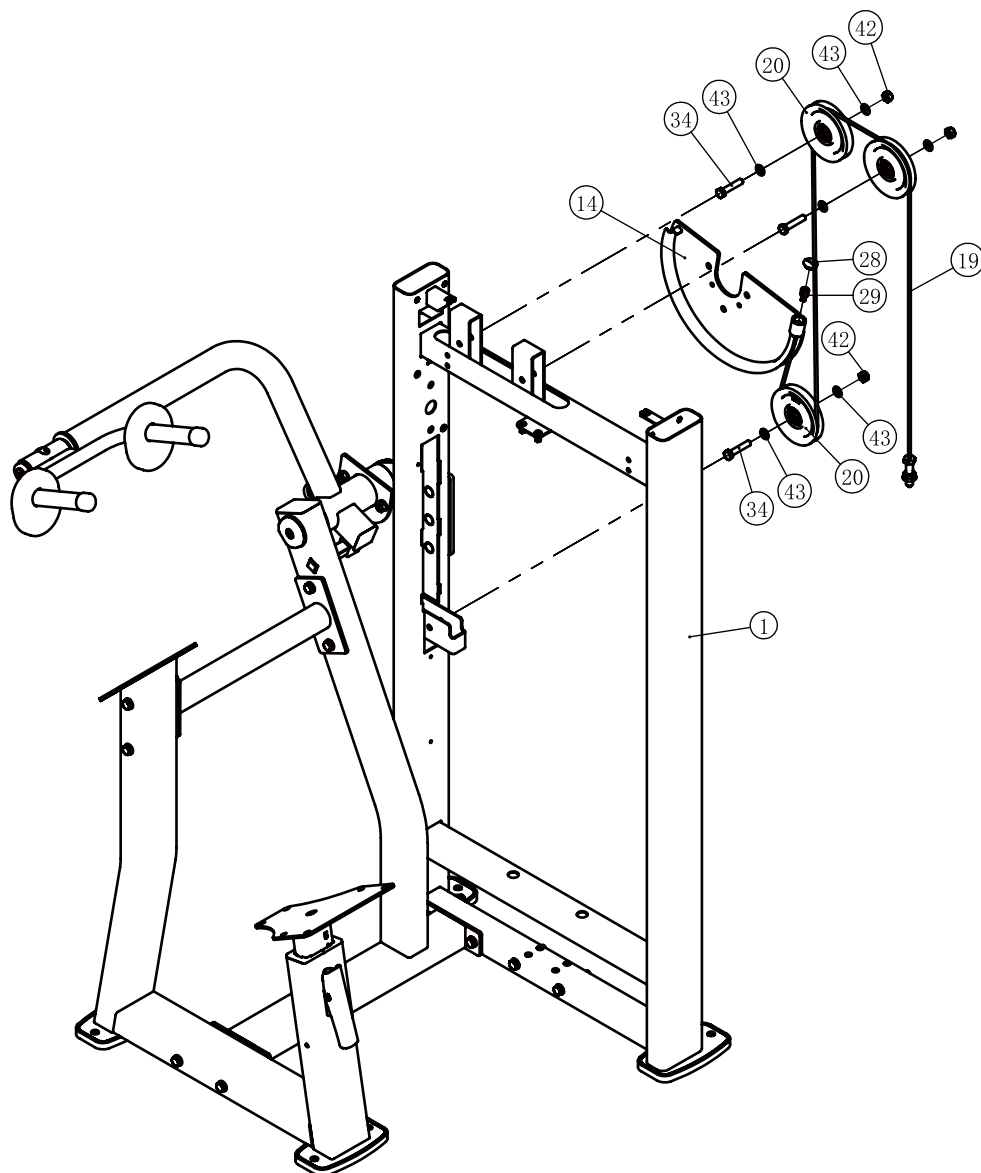

Assembly

STEP 4

Here is the assembly instruction for **160LBS Weights !**

1. Attach:

two Guide Rod $\Phi 19 \times 1097$ (#3) two Weight Rubber Bumper (#22)
 fifteen Weight Plate 10LBS (#101) two weight stack space (#103)
 one Top Plate (#2)
 to the Weight Stack Frame ASSY (#1) using:
 two Guide Rod Fixing Sleeve $\Phi 25 \times \Phi 19 \times 45$ (#23)
 two Spring (#24)

2. Attach the Selector Pin W/Coil (#21) to the Top Plate (#2).

3. Attach the Cable ASSY (#19) to the Top Plate (#2).

4. Attach the First Weight Plate 10LBS (#101) to the Top Plate (#2) using:
 one Spring Pin $\Phi 11 \times 76$ (#25)

Grade No.	Part No.	Description	QTY
101	FE97193100	10LBS Weight Plate	15
103	FEWS01ASSY	Weight Stack Space	2

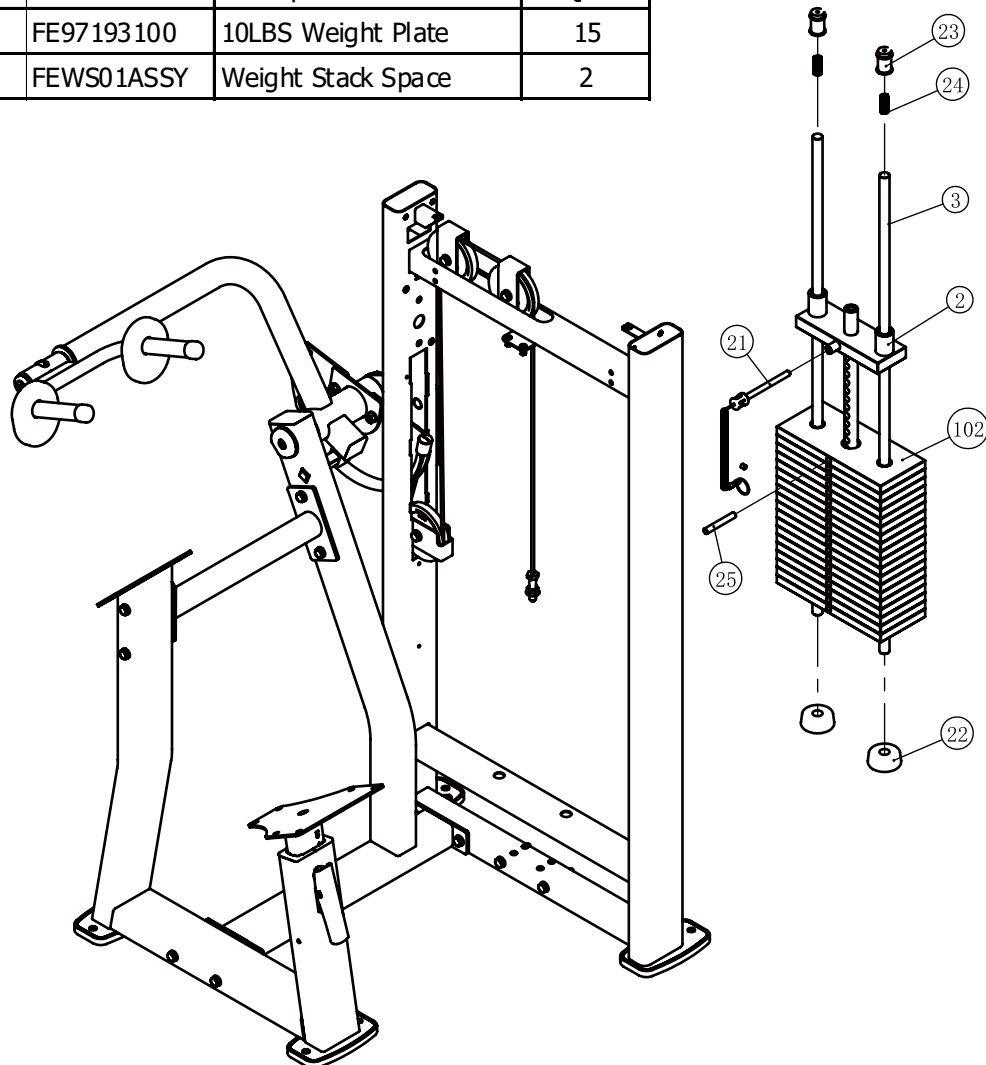

Assembly

STEP 4

Here is the assembly instruction for **200LBS Weights !**

1. Attach:

two Guide Rod $\Phi 19 \times 1097$ (#3) two Weight Rubber Bumper (#22)
 nineteen Weight Plate 10LBS (#101) one Top Plate (#2)
 to the Weight Stack Frame ASSY (#1) using:
 two Guide Rod Fixing Sleeve $\Phi 25 \times \Phi 19 \times 45$ (#23)
 two Spring (#24)

2. Attach the Selector Pin W/Coil (#21) to the Top Plate (#2).

3. Attach the Cable ASSY (#19) to the Top Plate (#2).

4. Attach the First Weight Plate 10LBS (#101) to the Top Plate (#2) using:
 one Spring Pin $\Phi 11 \times 76$ (#25)

Grade No.	Part No.	Description	QTY
101	FE97193100	10LBS Weight Plate	19

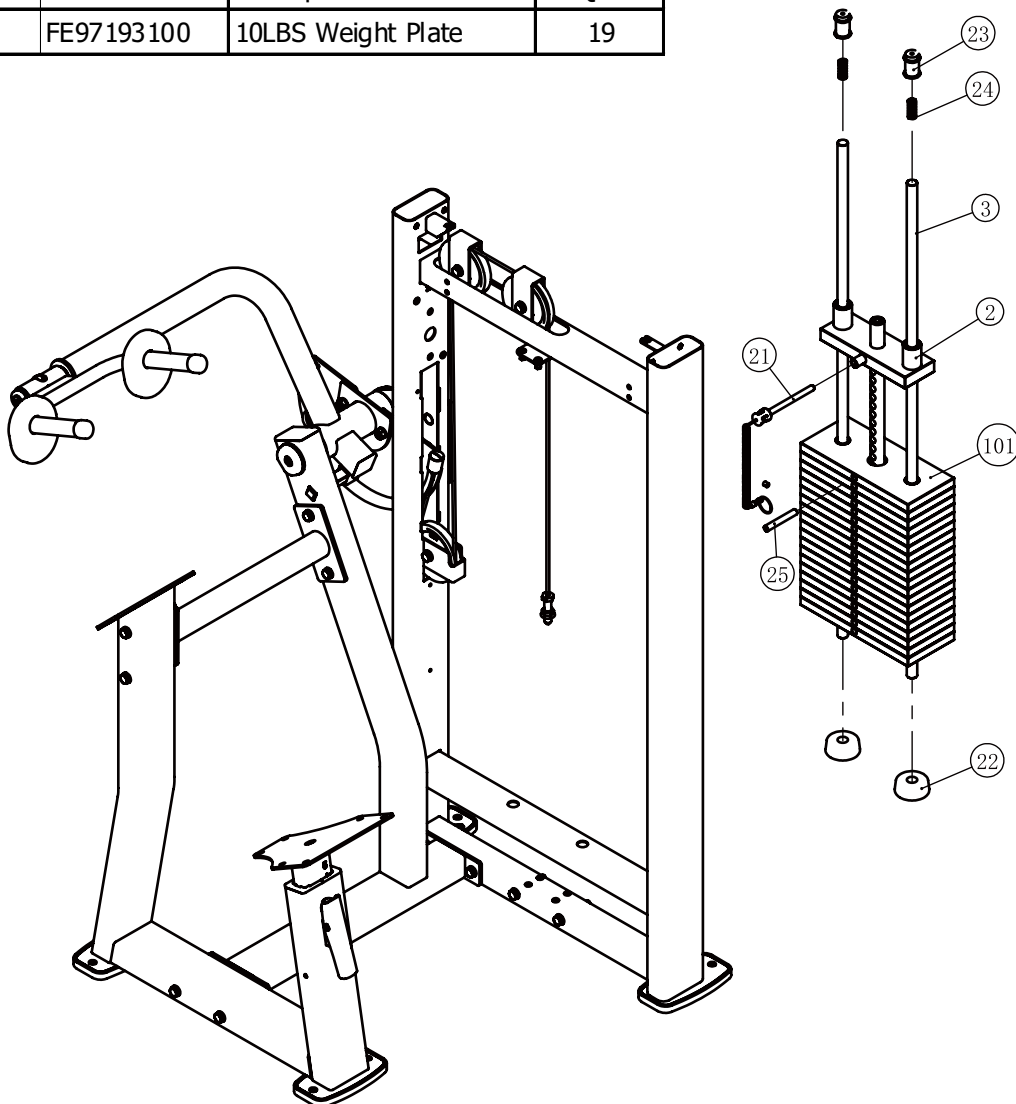

Assembly

STEP 4

Here is the assembly instruction for **235LBS Weights !**

1. Attach:

two Guide Rod $\Phi 19 \times 1097$ (#3) two Weight Rubber Bumper (#22)
 fifteen Weight Plate 15LBS (#102) two weight stack space (#103)
 one Top Plate (#2)
 to the Weight Stack Frame ASSY (#1) using:
 two Guide Rod Fixing Sleeve $\Phi 25 \times \Phi 19 \times 45$ (#23)
 two Spring (#24)

2. Attach the Selector Pin W/Coil (#21) to the Top Plate (#2).

3. Attach the Cable ASSY (#19) to the Top Plate (#2).

4. Attach the First Weight Plate 15LBS (#102) to the Top Plate (#2) using:
 one Spring Pin $\Phi 11 \times 76$ (#25)

Grade No.	Part No.	Description	QTY
102	FE97193200	15LBS Weight Plate	15
103	FEWS01ASSY	Weight Stack Space	2

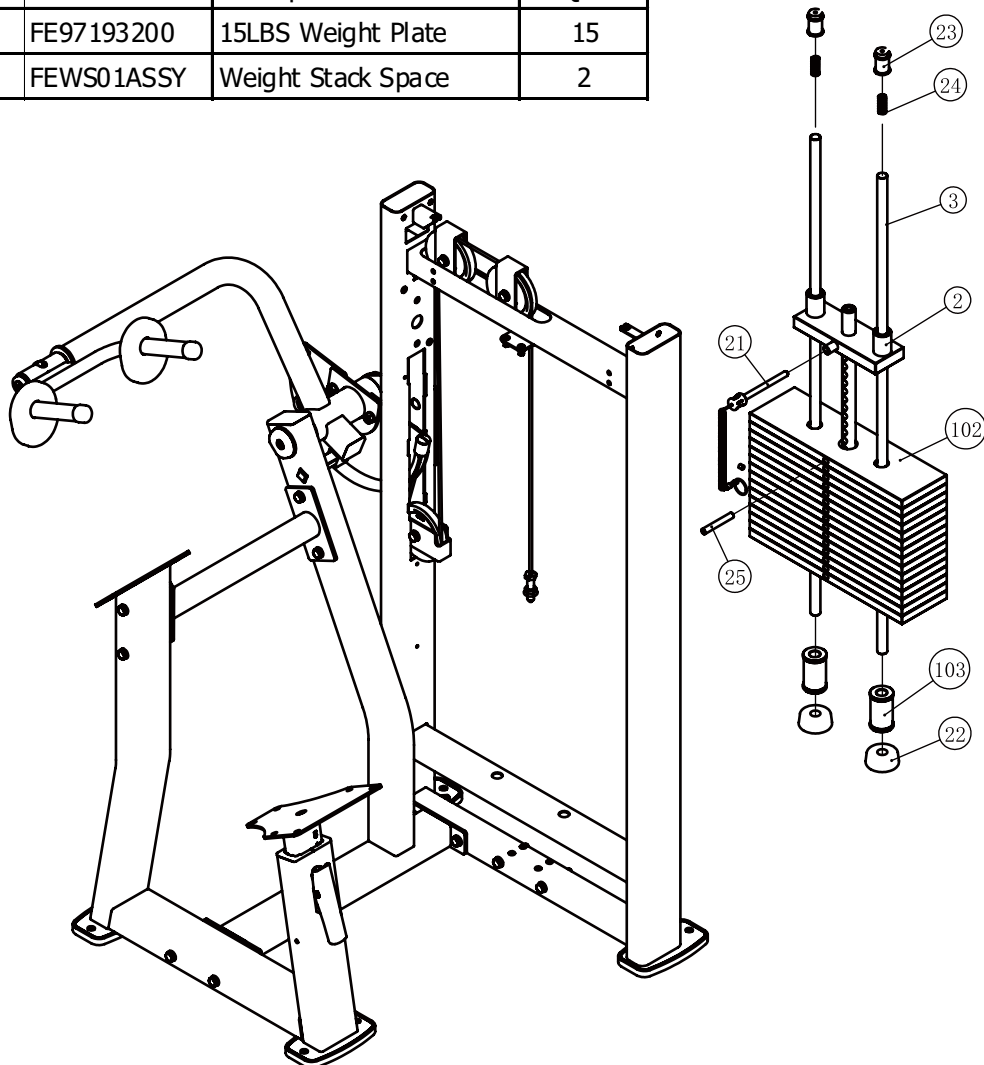

Assembly

STEP 4

Here is the assembly instruction for **295LBS Weights !**

1. Attach:

two Guide Rod $\Phi 19 \times 1097$ (#3)

two Weight Rubber Bumper (#22)

nineteen Weight Plate 15LBS (#102)

one Top Plate (#2)

to the Weight Stack Frame ASSY (#1) using:

two Guide Rod Fixing Sleeve $\Phi 25 \times \Phi 19 \times 45$ (#23)

two Spring (#24)

2. Attach the Selector Pin W/Coil (#21) to the Top Plate (#2).

3. Attach the Cable ASSY (#19) to the Top Plate (#2).

4. Attach the First Weight Plate 15LBS (#102) to the Top Plate (#2) using:

one Spring Pin $\Phi 11 \times 76$ (#25)

Grade No.	Part No.	Description	QTY
102	FE97193200	15LBS Weight Plate	19

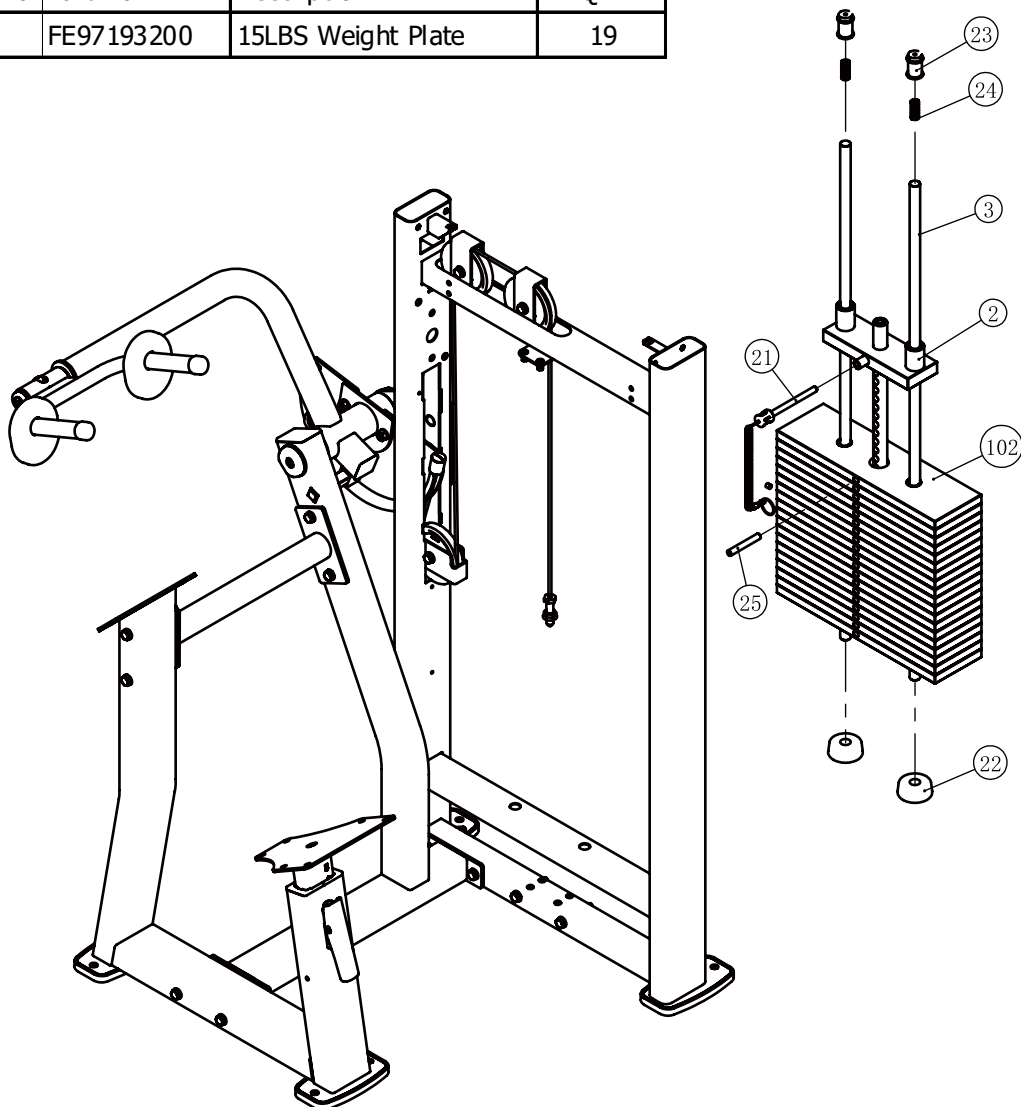

Assembly

All weight plate sticker paste schematic diagram

LBS 20	9
LBS 30	14
LBS 40	18
LBS 50	23
LBS 60	27
LBS 70	32
LBS 80	36
LBS 90	41
LBS 100	45
LBS 110	50
LBS 120	54
LBS 130	59
LBS 140	64
LBS 150	68
LBS 160	73
LBS 170	77
LBS 180	82
LBS 190	86
LBS 200	91
LBS 210	95
LBS 220	100
LBS 230	104

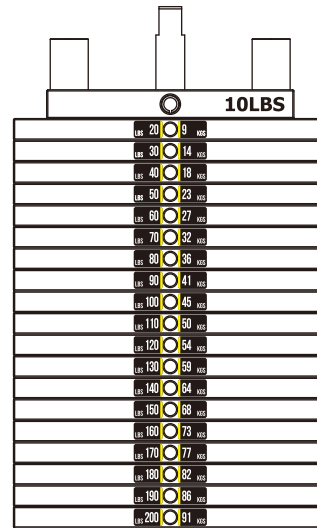
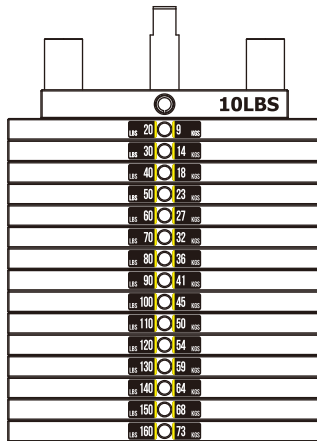

LBS 25	11
LBS 40	18
LBS 55	25
LBS 70	32
LBS 85	38
LBS 100	45
LBS 115	52
LBS 130	59
LBS 145	66
LBS 160	72
LBS 175	79
LBS 190	86
LBS 205	93
LBS 220	100
LBS 235	107
LBS 250	113
LBS 265	120
LBS 280	127
LBS 295	134
LBS 310	141
LBS 325	147

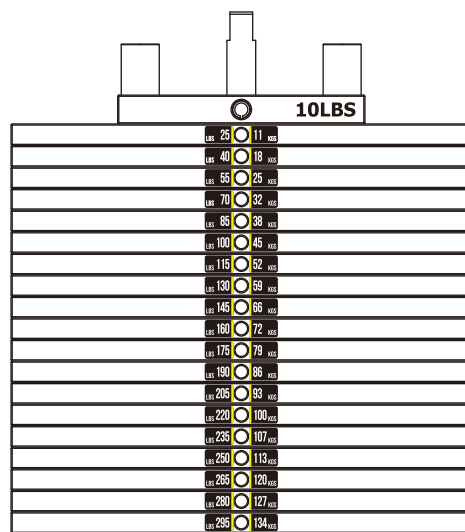
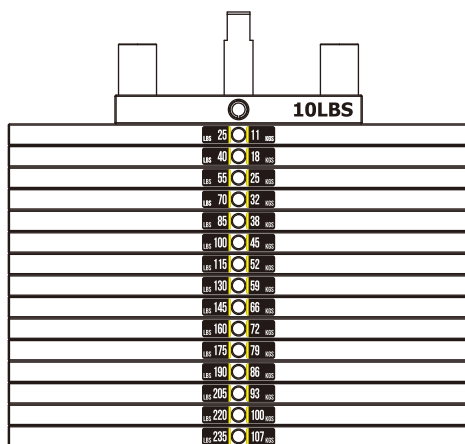

Assembly

STEP 5

1. Attach the Front Bracket ASSY (#4), the Bottom Bracket ASSY (#9), Right Bracket ASSY (#8) and the Left Bracket ASSY (#7) to the Weight Stack Frame ASSY (#1) using:
eight ST4.2*16 Cross Disc Self Tapping Screw (#41)
two M10*75 HHB (#33)
four $\Phi 11*\Phi 20*2$ Flat Washer (#43)
two M10 Nylon Lock Nut (#42)
2. Attach the Spout Plug (#6) to the Weight Stack Frame ASSY (#1).
3. Attach the Rear Shroud (#46), the Front Shroud (#45) and the Top Cover (#5) to the Weight Stack Frame ASSY (#1) using:
four Cross Disc Self Tapping Screw ST4.2*16 (#41)
twelve M6*20 CRPHS (#40)

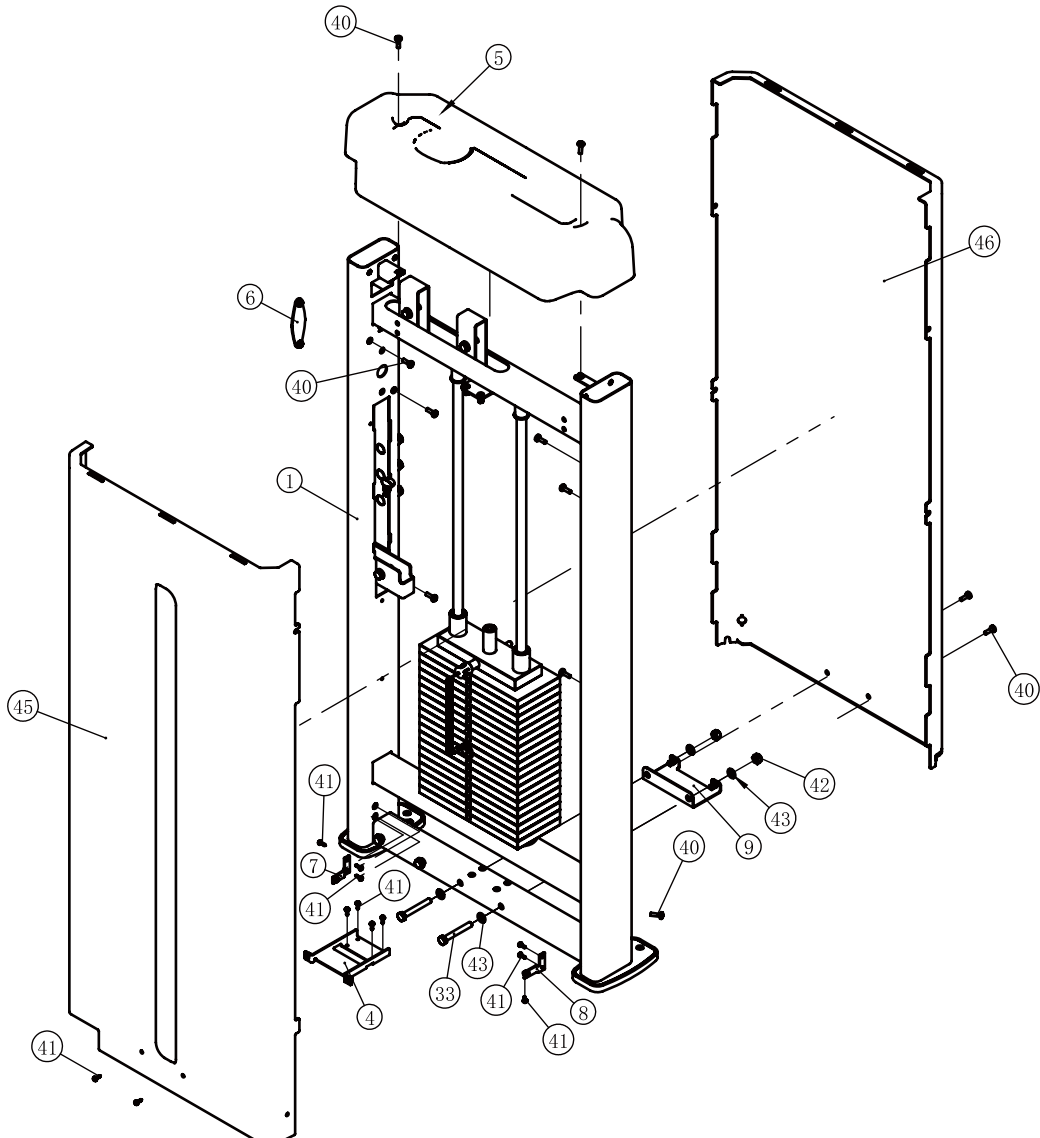

Assembly

STEP 6

Attach the Seat Pad (#48) and the Arm Pad (#47) to the Seat Pad Support (#10) and the Main Frame ASSY (#15) using:

- one Plate (#18) eight M10*30 HHB (#35)
- eight $\Phi 11*\Phi 20*2$ Flat Washer (#45)

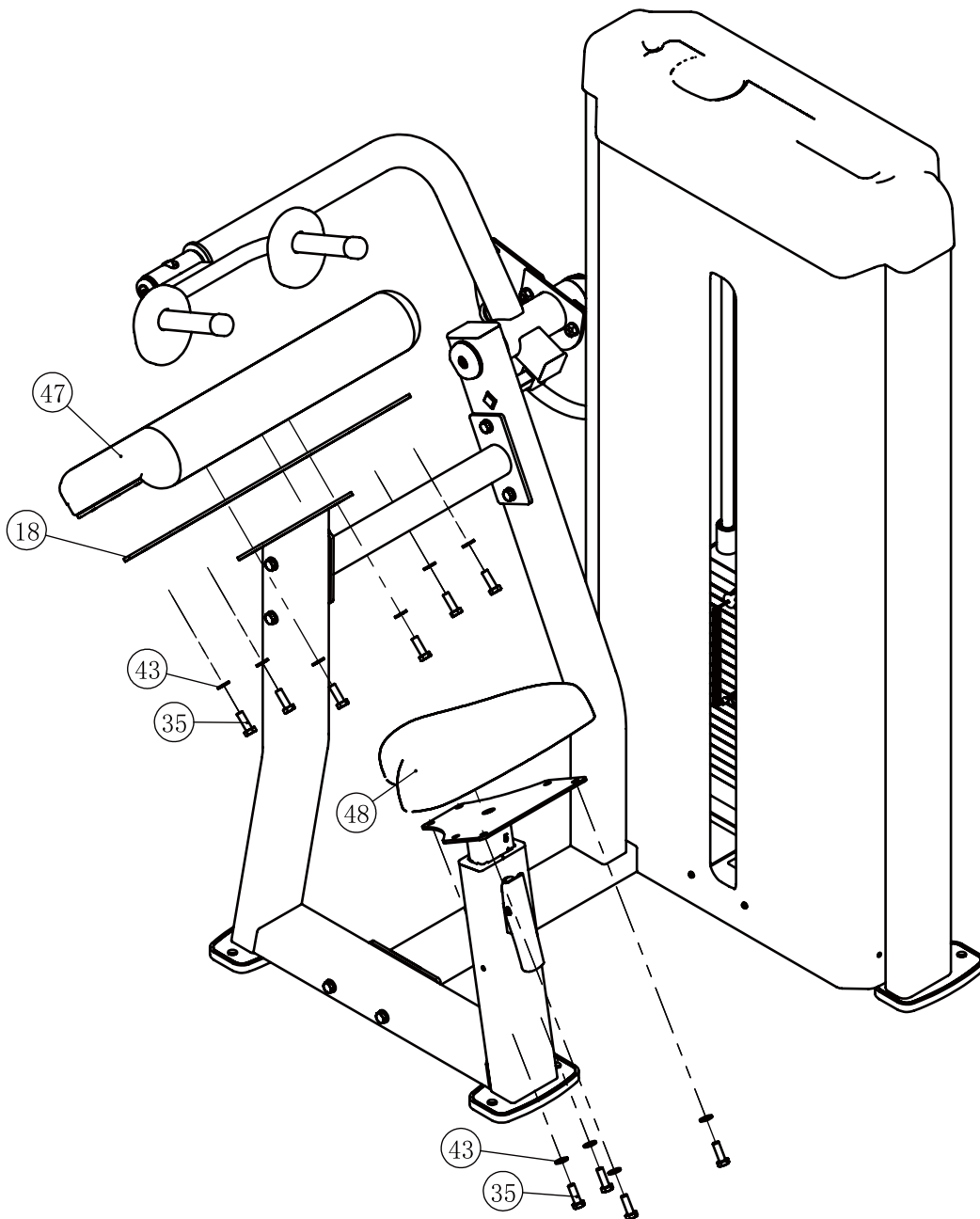

Adjust Instructions and Exercise Instructions

The Seat Pad adjustment

1. Pull the Adjustable Handle and adjust the Seat Pad to the desired position.
2. Make sure the pin gets into the hole completely.

The use of Selector Pin W/Coil

1. Select an appropriate weight and put the Selector Pin W/Coil into the hole on it.
2. Make sure the Selector Pin W/Coil gets into the hole completely.

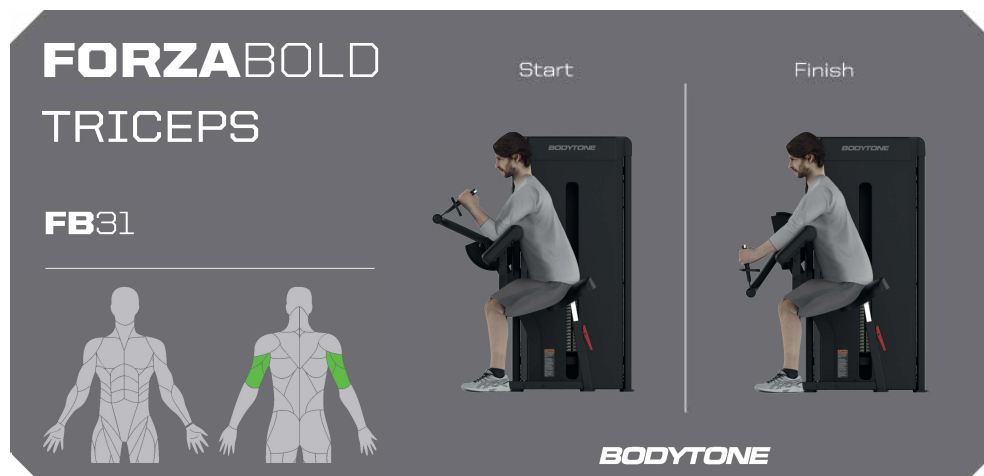
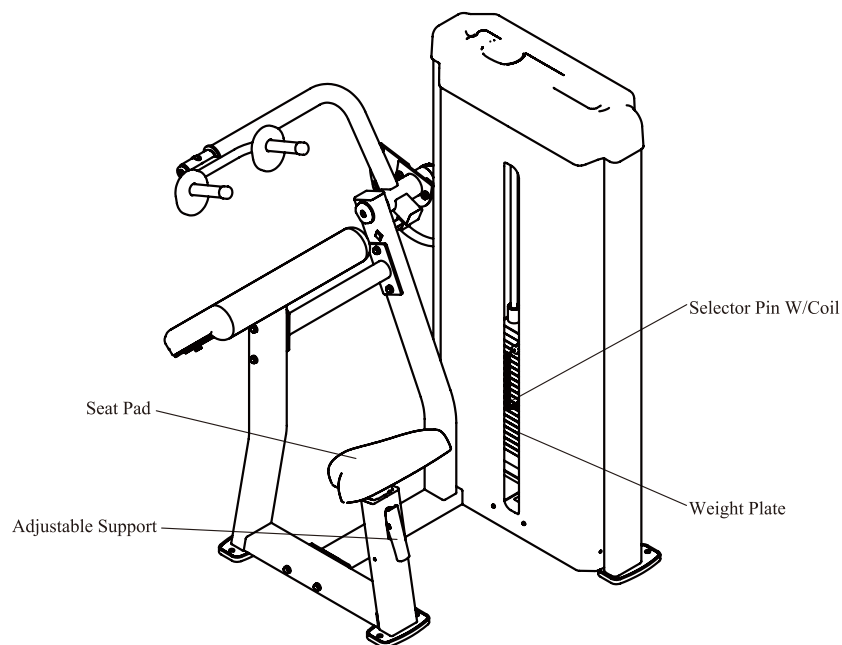

Maintenance Schedule

ROUTINE	COMMERCIAL MAINTENANCE	HOME MAINTENANCE	LATEST DATE ENTRY						
Inspect; Links, Pull Pins, Snap Locks, Swivels, Weight Stack Pins	DAILY	WEEKLY							
Clean; Upholstery	DAILY	WEEKLY							
Inspect; Cables or Belts and their tension	DAILY	WEEKLY							
Inspect; Accessory Bars, and Handles	WEEKLY	3 MONTHS							
Inspect; All Decals	WEEKLY	3 MONTHS							
Inspect; All Nuts and Bolts, Tighten if needed	WEEKLY	3 MONTHS							
Inspect; Anti-Skid Surface	WEEKLY	3 MONTHS							
Clean & Lubricate; Guide Rods with a Teflon (PTFE) based lubricant (Superlube)	MONTHLY	3 MONTHS							
Lubricate; Seat Sleeves, Turcite Bushings, Linear Bearing	MONTHLY	3 MONTHS							
Clean and Wax; All Glossy Finishes	6 MONTHS	YEARLY							
Repack with Grease; Linear Bearings	6 MONTHS	YEARLY							
Replace; Cables, Belts and Connecting Parts	YEARLY	3 YEARS							

Your equipment comes with a commercial maintenance decal. For personal, in home use, please follow the home maintenance schedule listed above.

General Maintenance Information

Links, Pull-Pins, Snap Hooks, Swivels, Weight Stack Pins:

- * Check all pieces for signs of visible wear or damage.
- * Check springs in snap hooks and pull-pins for proper tension and alignment.
- * If the spring sticks or has lost its rigidity, replace it immediately.

Upholstery:

- * To ensure prolonged upholstery life and proper hygiene, all upholstered pads should be wiped down with a damp cloth after every workout.
- * Periodically take the time to use a mild soap or an approved vinyl upholstery cleaner to deter the onset of cracking or drying. Avoid using any abrasive cleaners or cleaners not intended for use on vinyl.
- * Replace ripped or worn upholstery immediately.
- * Keep sharp or pointed objects clear of all upholstery.

Decals:

- * Inspect and familiarize yourself with any safety warnings or other user information posted on each decal.

Nuts and Bolts:

- * Inspect all nuts and bolts for any loosening and tighten if needed.
- * Go through a re-tightening sequence periodically to ensure that all hardware is tensioned proper.

Anti-Skid Surfaces:

- * These surfaces are designed to supply secure footing and need to be replaced if they appear worn or become slippery.

Belts and Cables:

- * We use only high quality belt, and mil-spec cables.
- * Visually inspect the belts and cables for fraying, cracking, peeling or discoloration.
- * While the machine is not in use, carefully run your fingers along the belt or cable to feel for thinning or bulging areas.
- * Replace belts and cables immediately at the first signs of damage or wear. Do not use equipment until belts or cables have been replaced.

Belt and Cable Tension:

- * Referring to the Owners Manual, when belts or cables are used check all bolt attachments to be sure they are properly attached.
- * Check slack in cables and re-adjust cable tension if needed.

Seat Sleeves, Guide Rods:

- * Wipe down adjusting tubes with a dust free rag before applying lubricant.
- * Lubricate seat sleeves and Guide Rods with a Silicon or Teflon based lubricant spray.

Linear Bearings:

- * Referring to the Owners Manual carefully disassemble the bearing from its housing and place a finger full of light grease (lithium, super lube, etc.) into the inside of the bearing. Using your finger, press the grease into the ball-bearings and their tracks. Repeat until the ball-bearing tracks are full of grease. Insert the shaft back into the bearing and wipe off excess grease.

PLEASE KEEP THIS FOR YOUR RECORDS

Weight Training Tips

Use this manual to guide you through the basic exercises you can perform on your equipment. To gain maximum results and avoid possible injury, consult a fitness professional to develop your complete exercise program.

Always consult your physician before starting any exercise program.

To be successful in your exercise program, it is important to develop an understanding of the basic principles of strength training. Now that you have your equipment, it is only natural that you want to get started immediately. First, determine a set of realistic goals and objectives for yourself. By deciding on an exercise plan that is right for you prior to starting, you will contribute significantly to your success.

Warm up properly before engaging in weight resistance training. Stretching, yoga, jogging, calisthenics or other cardiovascular exercise can help prepare your body for the heavier workload of lifting weights.

Learn how to perform the exercise correctly before using heavy weight. Correct form is important to avoid injury and to ensure that you work the proper muscle groups.

Know your limitations. If you are new to weight training or are embarking on an exercise regimen after a long layoff, start slowly and build foundational strength over a longer period of time.

Pay attention to your breathing. Exhale when you exert is a general rule of thumb. Never hold your breath.



BODYTONE



bodytone.eu