

USER MANUAL

ACTIVE RUN 200 CONNECT



bodytone

CONTENT

1. Product Introduction	3
2. Security Considerations	6
3. Installation Steps	7
4. Sports Tips and Guiding Principle	10
5. Product Instructions	11
6. Product Maintenance	13



WARNING

Read this manual before using the equipment.

Name of the Product	Motorized Treadmill
Number of the Model	Active Run 200 Connect

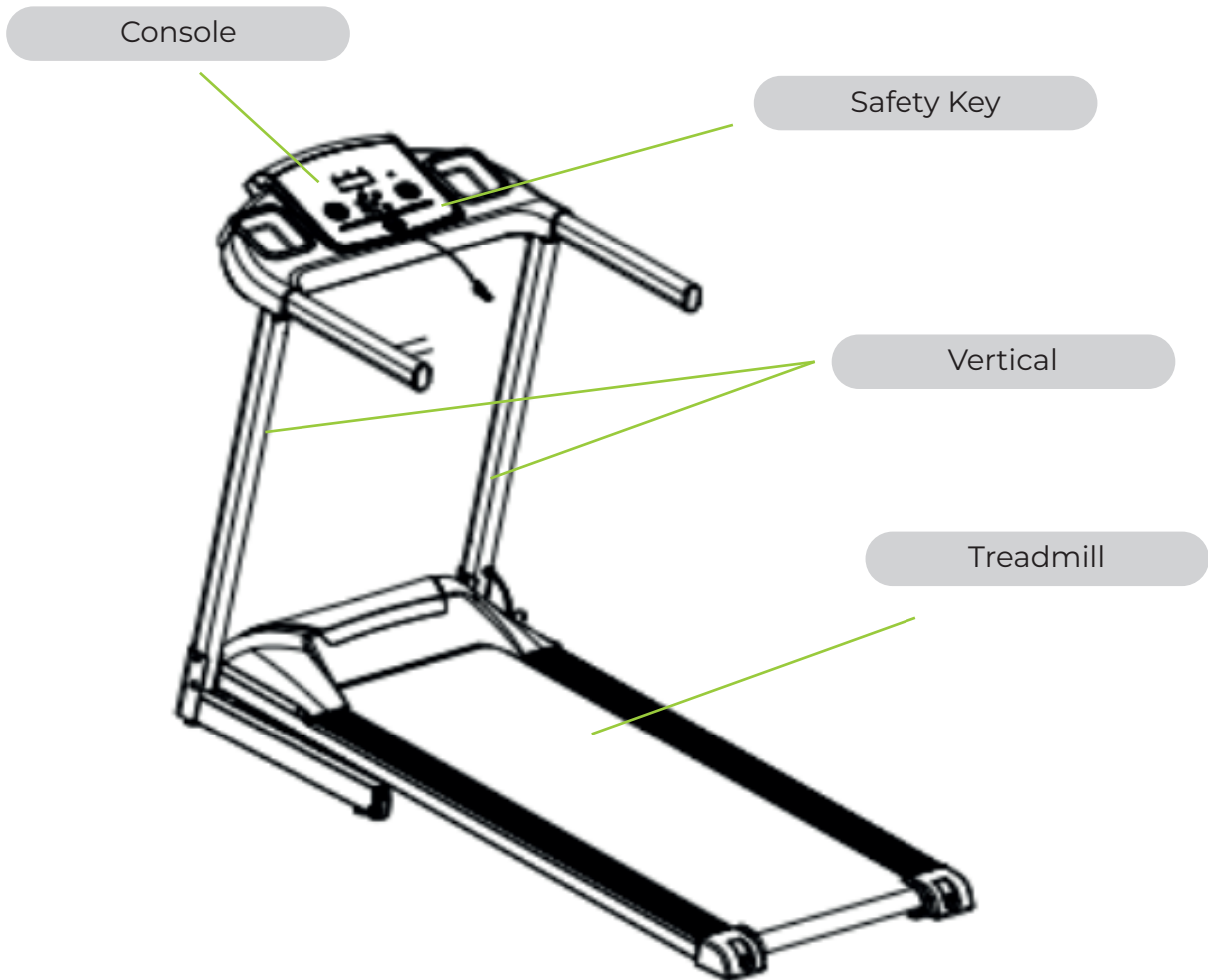

N°	Technical Parameters	
1	Career Area	1200 x 400 mm
2	Expand Size	1632 x 665 x 1147 mm
3	Voltage/Frequency	AC220V (50~60 Hz)
4	Speed	0.8 -12 Km/h
5	Function	Execute/Audio

Items Number List			
1	Internal hexagonal nut 6mm M8x50	2	Horizontal pipe upward
2	Internal hexagonal nut 6mm M8x40	6	Reparation of U pipes
3	Internal hexagonal nut 6mm SM8x65	2	Fixed Upright
4	U-shaped tube cap	4	
5	Handrail cover	2	
6	5mm/6mm inner hexagon wrench	2	
7	Multifunctional screwdriver	1	
8	Opening key	1	13# 15#
9	Oil	1	30ml
10	8x65 functional support	2	
11	6mm inner hexagon nut M8x20	6	

N°	Name	
1	Complete (Base, Vertical, Meters)	1
2	Accessories bag	1
3	Manual/Warranty Card	2

2. SAFETY NOTICES AND WARNINGS



NOTICE: Please read the instruction book carefully before use and note the following safety issues.

1. The treadmill is suitable for placing in the room to avoid moisture. It cannot be splashed by water and cannot avoid any foreign material.
2. Before exercising, wear appropriate sports clothing and sports shoes. It is prohibited to run on the machine with bare feet and it is prohibited to stretch the entire body on it.
3. The power plug must be reliable and grounded. The socket base must have a special circuit to prevent it from being shared with other electrical equipment.
4. Keep children away from the machine in case of accidents.
5. Avoid overload operation for a long time, otherwise it will damage the motor and controller and accelerate the wear and aging of the bearing, belt and footboard. Maintain the machine periodically.
6. Reduce indoor dust and maintain certain humidity in the room in case of strong static. Otherwise, it may disturb the normal operation of the electronic watch and controller.
7. After using, turn off the machine.
8. When exercising, attach the safety lock cable to your clothing, so that the machine can be turned off safely when an emergency occurs.
9. If you feel uncomfortable or anything abnormal in the process of using, please stop exercising and consult your doctor.
10. After using silicone oil, keep it in a place out of reach of children to avoid serious results caused by accidental ingestion.



WARNINGS: To reduce accidents or injuries to third parties, observe the following rules:

1. Before using the machine, check whether the clothes are buttoned or closed.
2. Do not wear clothing that is easily caught in the machine.
3. Do not bring the power line close to hot objects.
4. Do not make children near the treadmill.
5. Do not use the treadmill outdoors.

6. Power must be turned off before moving the treadmill.
7. Non-professionals are not allowed to disassemble the machine, otherwise serious results may occur.
8. This treadmill can only be used on the 20 amp circuit.
9. When the machine starts, only one person can exercise on it.
10. During exercise, if you feel dizziness, chest pain, nausea or shortness of breath, stop exercising immediately and consult your appropriate fitness trainer or doctor.



WARNINGS: For people receiving medical treatment or the following patients, please talk to special doctors before use.

1. People who suffer from back pain or who suffered injuries to their legs, waist or neck. People who suffer from numbness in the legs, waist, neck and hands (people who have long-standing diseases such as herniated disc, herniated spine, cervical protrusion, etc.)
2. People who have deformed arthritis, rheumatism, gout.
3. People who have osteoporosis abnormalities.
4. People who have circulatory system problems (heart disease, blood vessel dysfunction, high blood pressure, etc.)
5. People who have problems with the respiratory organs.
6. People who use artificial pacemakers to implant electrical medical instruments into the body.
7. People who have pathologies.
8. People who suffer from blood circulation disorders such as thrombosis or severe dynamic fatty tumor, still acute fatty tumor, etc., or all types of skin infections.
9. People who have perceived barriers caused by very peripheral circulatory obstacles that are caused by diabetes, etc.
10. People who have skin lesions.
11. People who have high fever (less than 38°) caused by illness, etc.
12. People who have spinal abnormalities or spinal flexion.
13. People who are pregnant or may be pregnant or who are on their period.
14. People who have abnormalities in the body and need to rest.
15. People whose health is obviously poor.
16. People who aim to recover.
17. During the exercise process, if you feel pain, such as waist pain, leg and foot numbness, dizziness, heartbeat that is different from normal times, or abnormal tightness, please stop using it immediately and consult to your doctor.

18. During the exercise process, if you feel pain, such as waist pain, leg and foot numbness, dizziness, heartbeat that is different from normal times, or abnormal tightness, please stop using it immediately and consult to your doctor.
19. Do not allow children to use this product and keep them away from the product. If not observed, there may be a risk of injury.
20. When using, carrying or taking out the product, or moving it, please confirm whether there are people or pets around (back, bottom, front of the product)



PROHIBITIONS

1. Do not use when the casing cracks and falls apart (internal structure is exposed) or welded parts fall off.
2. During exercise, do not jump up or down. Otherwise, injuries may be caused by falls.
3. Do not use or store it in humid places outdoors or near the bathroom.
4. Do not use or keep it in direct sunlight, high temperature places such as around the stove, or on heating instruments such as an electric blanket. Otherwise, it may cause electric shock or fire.
5. Do not use when the power line or plug is damaged or the plug base has become loose. Otherwise, it may cause fire or electric shock.
6. It cannot be used simultaneously by two people or more than two people. During use, do not allow people nearby. Otherwise, falls may cause accidents or injuries.
7. People who cannot express their consciousness or cannot operate it cannot use it. Otherwise, it may cause accidents or injuries.
8. Avoid touching water. The main body or operating part cannot be wet with water or drink. Otherwise, it may cause electric shock or fire.
9. Special attention to people not used to intense sports practices.
10. Do not use it after meals, when you feel tired, shortly after exercising or physical strength is abnormal. Otherwise, it may harm health.
11. This product is suitable for home use and not suitable for some unspecified places, such as schools, gyms, etc. Otherwise there may be a risk of injury.
12. Do not wear it when you are eating or doing other activities.
13. Do not use it when you feel dizzy after drinking alcohol. Otherwise it may cause accidents or injuries.
14. Do not use with wet hands. Do not remove or insert the plug with wet hands. Otherwise, it may cause electric shock or injury.
15. When not in use, remove the plug from the socket. Otherwise, dust and moisture will degrade the insulation, resulting in electric shock and fire.

16. Do not remove or insert the plug with wet hands. Otherwise, it may cause electric shock or injury.
17. Pull out the plug from the socket when not in use. Otherwise, dust and moisture will degrade the insulation and increase the chances of electrical leaks and fires..



GROUNDING INSTRUMENT

This product must be grounded. If the machine fails, the ground will provide a path of least resistance for current to reduce the danger of electric shock.

This product is installed with an equipment grounding conductor and a grounding plug. The plug must be inserted into the appropriate outlet that has been properly installed and grounded in accordance with local laws or regulations.

3. INSTALLATION STEPS

When installing, first simply fix all the screws to the frame and stand it upright.

STEP 1

Lift the vertical supports of the tape and fix it with 2 M8*40 screws with 2 M8 nuts and 4 M8*20 screws. One on each side of the ribbon as shown in the picture.

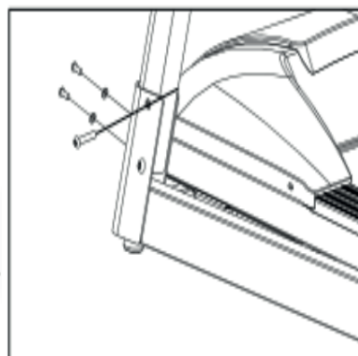

STEP 2

Screw the handles on both sides with M8*20 Screw to put the machine arms and console in position.



STEP 3

Insert the provided security pin into the yellow marking hole on the console below the screen. It is now ready for use.

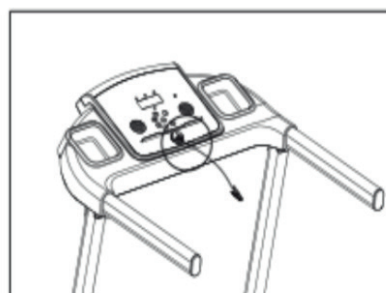

4. PRE-EXERCISE TIPS

HEATING

Please warm up for 5 to 10 minutes before using this machine each time.

BREATHING

When you exercise, you cannot hold your breath, you usually inhale with your nose when trying to perform actions and exhale with your mouth. Inhalation must be coordinated with exhalation. If you breathe too fast, you should stop exercising immediately.

FREQUENCY

After exercising the same parts of the muscles, this part should rest for 48 hours. That is, it is advisable to exercise on alternate days.

BURDEN

Decide the training volume based on everyone's physical fitness training status, and then exercise according to the principle of progressive overload. In the first stage of exercise, muscle soreness is normal and can be eliminated by continuing to exercise.

DIET

To protect the digestive system, exercise should be performed one hour after a meal. You should eat at least half an hour after exercising. When you exercise, drink less water and, above all, avoid drinking too much water so as not to increase the load on the heart and kidneys.

STRETCHING EXERCISE

Whatever your running speed, you'll want to do some stretching exercises first. Trained muscles are easier to stretch, so walk for 5 to 10 minutes to train them. Then stop stretching exercises five times according to the following methods, 10 seconds or more for each leg, and do it again after exercising.

STRETCHING EXERCISE

- 1. DOWNWARD STRETCH:** Bend your knees slightly and slowly bend your body downward. Relax your back and shoulders, touch your legs and toes as closely as possible with your hands. Hold for 10 to 15 seconds and then relax. Repeat three times.
- 2. Hamstring Stretch:** Sit on a cushion, stretch one leg straight, bend the other leg inward to adhere to the inner side of the straight leg. Touch the leg and toes as close as possible with your hand. Hold for 10 to 15 seconds and then relax. Repeat each leg three times.
- 3. SHAFT AND HEEL TENDON STRETCH:** Stand with two hands on the wall or desk and one foot back. Keep your back leg straight and heel touching the floor, leaning toward the wall or desk, hold for 10 to 15 seconds, then relax. Repeat each leg three times.
- 4. HEAD MUSCLES STRETCH:** Put your right hand on the wall or desk, then stretch your left hand back. Hold your left ankle and pull it up to your hip until you feel the front muscles of your upper leg are tight, pull for about 10 to 15 seconds and then relax. Repeat three times for each leg.
- 5. SARTORIUS STRETCH:** (inner lateral leg muscles) Sit with your lower legs against each other and your knees facing outward. Support your feet with your hands. Pull into the abdominal groove, hold for 10 to 15 seconds, and then relax. Repeat three times.

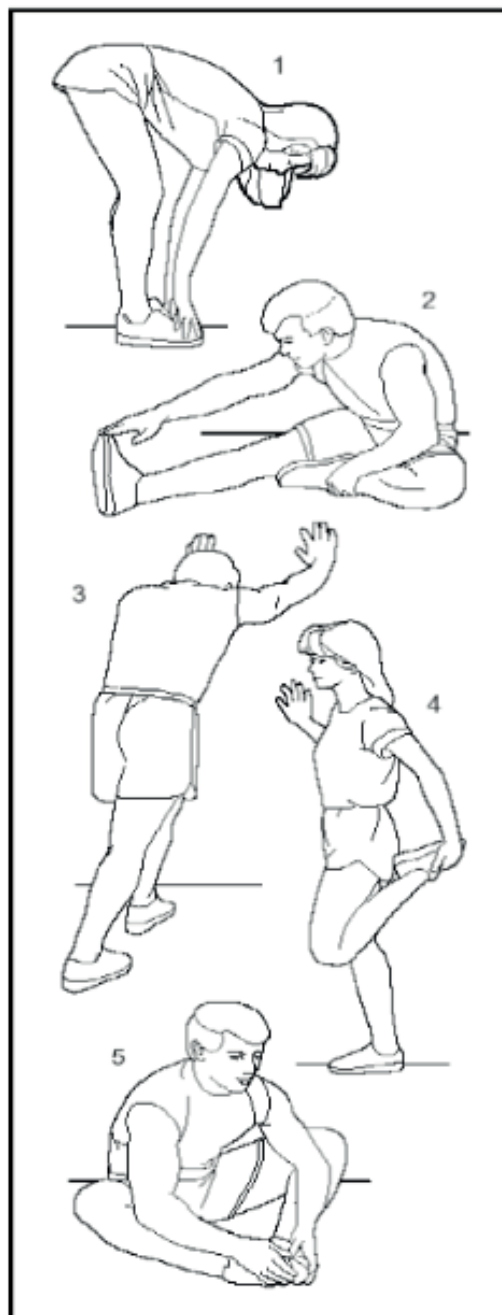

5. PRODUCT INSTRUCTION



CONSOLE

SPEED: Sounded 0.8-12.0 KM/H. The LCD screen will display the numbers 3,2,1 and then the treadmill will start. Settings and data are displayed on the LCD screen.

TIME

Manual model: Setting time from 0 to 100 minutes or "end" is displayed on the LCD screen. The speed of the treadmill will be slow stably and the waiting time after 5 minutes.

Distance and calorie model: 0 to 100 minutes or "end" setting is displayed on the LCD screen and finished well. Keep moving. If you set 100-0 minutes or "end" displayed on the LCD screen, the speed of the machine will decrease stably and stop. Waiting time after 5 minutes.

DIS

Sports distance: 0-100 minutes setting or "end" display on LCD screen, slow down and stop stably. Waiting time after 5 minutes.

LIME

Expend calories: 0-999 or "end" are displayed on the LCD screen, slow down and stop stably. If you set 999-0 or "end", the treadmill will stop and time out after 5 minutes.

KEY FUNCTION

'SELECT' KEY:

Manual model: 0:00

Countdown Time model: 15:00 MIN: SECONDS.

Model countdown distance: 1.00 KM

Calories: 50.0

Internal procedure: P01-P12 operation.

'START' KEY: Start the treadmill whenever the power and secure grip of the key compete.

'STOP' KEY: Pressing it later. STOP the running treadmill.

SPEED: '+' this sign to increase speed. '-' this sign indicates that the speed will decrease. If you press it over 0.5 continue with the + or - sign, the speed will automatically increase or decrease.

SPEED, 5,8,12 is not displayed on the console. It means fast speed shortcut key. For example, you can adjust the speed 5 KM without problems.

QUICK START (MANUAL MODEL)

Follow the operation step by step.

ON/OFF > POST SECURITY KEY GRIP > HOME KEY > SPEED '+' OR '-' AND INCLINE '+' OR '-'

SECURITY LOCK FEATURES

In any state, if you remove the safety lock, it can immediately stop the motor running and then the time window will show "-----" marks, and the buzzer will make alarm "B1-B1-B1" sound . At this point, except for shutdown, no other operations can be implemented on the treadmill. As long as the safety lock is successfully reinstalled, the treadmill will enter standby mode again and wait for the command to be entered.

Before exercising, you should first inspect whether the treadmill has the power supply charged, and then check whether the safety lock is effective.

If abnormal situations occur during movement, you can remove the safety lock and then the treadmill will quickly slow down to a stop. While the security lock is repositioned, this device will be repositioned waiting to enter the command.

SECURITY

In any circumstance, remove the safety switch, the system is idle and sends alarm sound (all windows show "-")

ATTACHED: SPORTS DIAGRAM OF THE P1-P12 PROGRAM

TIME PROG		To set time / 20 time = running time of each period																			
		1	2	3	4	5	6	7	8	9	10	11	12	13	14	15	16	17	18	19	20
P1	SPEED	2	3	3	4	5	3	4	5	5	3	4	5	4	4	4	2	3	3	5	3
P2	SPEED	2	4	4	5	6	4	6	6	6	4	5	6	4	4	4	2	2	5	4	1
P3	SPEED	2	4	4	6	6	4	7	7	7	4	7	7	4	4	4	2	4	5	3	2
P4	SPEED	3	5	5	6	7	7	5	7	7	8	8	5	9	5	5	6	4	4	3	3
P5	SPEED	2	4	4	5	6	7	7	5	6	7	8	8	5	4	3	3	6	5	4	2
P6	SPEED	2	4	3	4	5	4	8	7	5	7	8	3	6	4	4	2	5	4	3	2
P7	SPEED	2	3	3	3	4	5	3	3	5	3	4	5	3	3	3	6	6	5	3	3
P8	SPEED	2	3	3	6	7	7	4	6	7	4	6	7	4	4	4	2	3	4	4	2
P9	SPEED	2	4	4	7	7	4	7	8	4	8	9	9	4	4	4	5	6	3	3	2
P10	SPEED	2	4	5	6	7	5	4	6	8	8	6	6	5	4	4	2	4	4	3	3
P11	SPEED	3	4	5	9	5	9	5	5	5	9	5	5	5	5	9	9	8	7	6	3
P12	SPEED	2	5	8	10	7	7	10	10	7	7	10	10	6	6	9	9	5	5	4	3

6. PRODUCT MAINTENANCE



Correct lubrication of the treadmill with silicone oil or Teflon is very important. It should be done regularly depending on each person, even before its first use.

LUBRICANT: The running belt should be lubricated with specially configured methyl silicone oil after use for a period of time.

1. Tip:

When the weekly use time is less than 3 hours, it should be lubricated once every five months.

When the weekly use time is 4 to 7 hours, it should be lubricated once every two months.

When the weekly use time is more than 7 hours, it should be lubricated once a month.

You cannot over-lubricate. It's not that the more lubricant the better. Remember: proper lubrication is the important factor in increasing the service time of the treadmill.

2. Lubrication methods

For the methods to examine whether lubricant is needed, you just need to grab the running belt and touch the middle part of the back of the belt with your hand as much as possible. If the strap has silicone resin (a little moisture) inside, it means no lubricant is needed; If the stirrup is dry and you do not feel silicone resin inside, it means that lubricant is needed.

A. Steps to coat the running board with lubricant: (see image)

B. Stop the rotation of the treadmill and fold the machine.

C. Lift the belt from the back of the body frame: stretch the oil holder as much as possible at the moving place of the belt, coat the inner side of the belt with silicone oil, and coat both sides of the belt with resin silicone, and then operate the treadmill at a speed of 1K M/H to evenly cover the silicone resin; and step on the belt from left to right for a few minutes, then the belt will completely absorb the silicone resin.

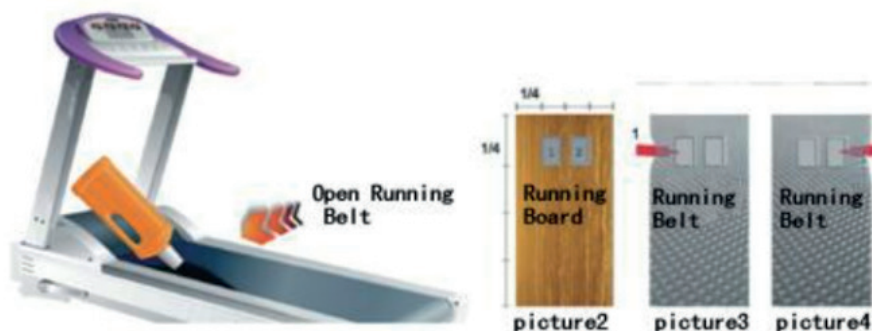

3. Running belt tension adjustment

All treadmill belts must be adjusted before leaving the factory and after installation; However, after a period of use, they may become loose. For example: when users are running, pause and slip may occur, if that happens, please adjust the belt and bolts synchronously from left and right side clockwise and with semicircle as unit; If the treadmill is too loose, slipping may occur between the belt and the roller when stepping on the belt; but if it is too tight, it will be easy to increase the load on the motor and damage the motor, tread, roller, etc.

4. Treadmill Deflection Adjustment

All machine belts must be adjusted before leaving the factory and after installation; However, after a period of use, belt deflection may occur, which is due to the following reasons:

The main engine is not evenly positioned.

The user's feet are not in the center of the running belt.

If the deflection phenomenon is caused by the uneven force of the user's feet, rotating without load for a few minutes can normalize it. For the deviation phenomenon that cannot return to normal automatically, adjust step by step using a 6mm inner hexagon wrench with the machine and with a quarter circle as a unit. Deviation of the treadmill is not covered by the scope of warranty and is mainly maintained by users according to the instruction book. The deviation phenomenon will seriously damage the running belt, so it must be detected and corrected in time..

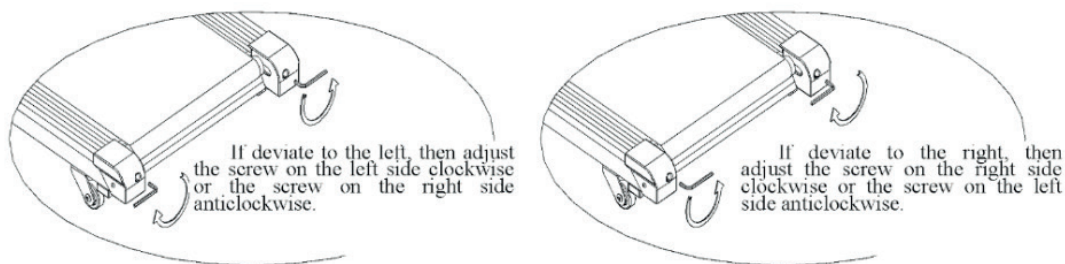

You must keep the original packaging with its protections, purchase receipt, manual and components during the warranty period.

7. FREQUENTLY ASKED QUESTIONS

Fault Code	Principal Reason	Solution
E01	The cable from the computer to the lower control board was not connected properly	<ol style="list-style-type: none">1. Check that the connection cable between the computer and the control board is securely connected.2. Make sure the IC on the control board is inserted well. If not, reinsert it.3. Abnormal power supply on the control board. Please change a new control board.
E02	Protect the explosion	<ol style="list-style-type: none">1. Bad contact with open motor circuit. Change a new motor or check the connector.2. The feeding tube was punctured. Change a new feed tube or control board.
E05	Overvoltage protection	<ol style="list-style-type: none">1. Overloaded.2. High resistance stirrup. Needs to be oiled3. Engine damage. Change a new engine.
E06	Control board self-test	
E08	EEPROM damage	Change the control board

bodytone